

---

# TS 700/4-i ; TS 700-G/4-i TS 1010-i

BASE DEVICES (MRF<sub>sc</sub>...) FOR THERMOSTAT CABINET (TS ...)

---



a xylem brand

**Copyright** © 2023, Xylem Analytics Germany GmbH  
Printed in Germany.

# Contents

<b>1</b>	<b>Safety</b>	<b>5</b>
1.1	Safety information	5
1.1.1	Safety information in the operating manual	5
1.1.2	Safety signs on the product	5
1.2	Safe operation	6
1.2.1	Authorized use	6
1.2.2	Requirements for safe operation	6
1.2.3	Unauthorized use	6
1.2.4	Dangers for the user	6
<b>2</b>	<b>Commissioning</b>	<b>9</b>
2.1	Included in delivery	9
2.2	Setup conditions	9
2.2.1	Setup location	9
2.2.2	Electrical connection	10
2.3	Transporting the appliance	10
2.4	Unpacking the appliance	11
2.5	Removing the transport lock	11
2.6	Setting up the appliance	11
2.7	Leveling out the appliance	12
2.8	Setting up multiple appliances	13
2.9	After setup	13
2.10	Disposal of packaging	13
2.11	Reversing the door	14
2.12	Aligning the door	25
2.13	Connecting the appliance	26
2.14	Switching on the appliance	26
2.15	Items for refrigeration	27
2.16	Safety lock	27
<b>3</b>	<b>Maintenance, cleaning</b>	<b>28</b>
3.1	Defrosting the appliance	28
3.2	Cleaning the appliance	28
3.2.1	Preparing	28
3.2.2	Cleaning the housing	29
3.2.3	Cleaning the interior	29
3.2.4	After cleaning	30
3.3	Shutting down	31

**4 What to do if... 32**

**5 Technical data 33**

5.1 General data 33

5.2 Electrical data 33

5.3 Dimensions, weight, equipment 34

**6 Disposal 35**

# 1 Safety

## 1.1 Safety information

### 1.1.1 Safety information in the operating manual

This operating manual provides important information on the safe operation of the product. Read this operating manual thoroughly and make yourself familiar with the product before putting it into operation or working with it. The operating manual must be kept in the vicinity of the meter so you can always find the information you need.

Important safety instructions are highlighted in this operating manual. They are indicated by the warning symbol (triangle) in the left column. The signal word (e.g. "CAUTION") indicates the level of danger:



#### **WARNING**

indicates a possibly dangerous situation that can lead to serious (irreversible) injury or death if the safety instruction is not followed.



#### **CAUTION**

indicates a possibly dangerous situation that can lead to slight (reversible) injury if the safety instruction is not followed.

#### **NOTE**

*indicates a situation where goods might be damaged if the actions mentioned are not taken.*

### 1.1.2 Safety signs on the product

Note all labels, information signs and safety symbols on the product.



The symbol may be located on the compressor.

It refers to the oil in the compressor and refers to the following danger: **Can be fatal if swallowed or inhaled.** This notice only applies for recycling. There is no danger during normal operation.



#### **WARNING:**

**Risk of fire / flammable materials.**

The symbol is located on the compressor and indicates the danger from flammable materials. Do not remove the label.

## 1.2 Safe operation

### 1.2.1 Authorized use

The authorized use of the TS 700...-i/1010-i thermostat cabinets consists exclusively of the use as a tempering instrument in water analysis. Only the operation and running of the instrument according to the instructions and technical specifications given in this operating manual is authorized (see chapter 5 TECHNICAL DATA). Any other use is considered unauthorized.

### 1.2.2 Requirements for safe operation

Note the following points for safe operation:

- The product may only be operated according to the authorized use specified above.
- The product may only be operated under the environmental conditions mentioned in this operating manual.
- The product may only be supplied with power by the energy sources mentioned in this operating manual.
- Live parts may only be repaired or changed by service personnel.

### 1.2.3 Unauthorized use

The product must not be taken into operation if:

- it is visibly damaged (e.g. after being transported)
- there is a leakage in the coolant circulation
- it was stored under adverse conditions for a lengthy period of time (storing conditions, see chapter 5 TECHNICAL DATA).

### 1.2.4 Dangers for the user

#### General instructions

- This appliance can be used by children aged 8 and above and people with impaired physical, sensory or mental abilities or with a lack of experience and knowledge provided that they are supervised or have received instruction regarding the safe use of the appliance and potential hazards. Children must not play with the appliance.
- Cleaning and user maintenance must not be performed by children unless they are supervised.
- The socket must be easily accessible so that the appliance can be disconnected quickly from the electricity in an emergency.
- It must not be located in the area behind the appliance.
- Always hold the plug of the cable when disconnecting the appliance from the power supply. Do not pull on the cable.

- Remove the plug or disconnect via the fuse if there is a malfunction.
- **WARNING:** Do not damage the power cable.
- Do not operate the appliance with a faulty power cable.
- **WARNING:** Multi-sockets/power distributors and other electronic appliances (such as halogen transformers) may not be placed and operated behind appliances.
- **WARNING:** Do not block the ventilation openings in the appliance housing or in the installation housing.
- Repairs, interventions on the appliance and the replacement of mains connection line may only be carried out by Customer Service or other suitably trained specialist personnel.
- Always follow the instructions when assembling, connecting and disposing of the appliance.

**Risk of fire**

- The refrigerant contained within the appliance (specifications on the type plate) is environmentally friendly, but flammable. Leaking refrigerant can ignite.
  - **WARNING:** Do not damage the refrigerant circuit. Do not handle ignition sources inside the appliance.
  - **WARNING:** Do not use electrical appliances inside the food storage compartments of the appliance, unless they are of the type recommended by the manufacturer.
  - If refrigerant leaks: Remove naked flames or ignition sources located near the area of the leak. Ventilate the room well. Contact Customer Service.
- Do not operate the appliance near explosive gases.
- Do not store or use gasoline or other flammable gases and liquids near the appliance.
- Do not store explosive substances such as aerosol cans with a flammable propellant in this appliance. You can recognize such spray cans by the printed list of contents or by a flame symbol. Any leaking gases can be ignited by electrical components.
- Keep lit candles, lamps and other objects with naked flames away from the appliance so they do not cause a fire.
- Alcoholic beverages or other containers holding alcohol must always be tightly sealed for storage purposes. Any leaking alcohol can be ignited by electrical components.

**Risk of falling or toppling over**

Do not stand on the base, drawers, doors etc. or use them as improper supports.

**Danger of frostbite, feeling of numbness and pain**

Avoid prolonged skin contact with cold surfaces or chilled/frozen food or take protective measures, e.g. wear gloves.

**Risk of injury and damage**

- **WARNING:** Do not use mechanical devices or other means to accelerate the defrosting process, other than those recommended by the manufacturer.
- **WARNING:** Risk of injury due to electric shock! There are live electrical parts under the cover. Have the LED interior lighting replaced or repaired only by Customer Service or other suitably trained professionals.\*
- **NOTE:** The appliance must only be operated using original manufacturer accessories or accessories from other providers approved by the manufacturer. The user bears the risk of using accessories which are not approved.

**Risk of crushing**

Do not reach into the hinge when opening and closing the door. Fingers may get trapped.

**Specialist personnel qualifications**

Specialist personnel are persons who, on account of their specialist training, knowledge and experience as well as their knowledge of the relevant standards, are able to assess and perform the work assigned to them and identify potential hazards.

They must have training, instruction, and authorization to work on the appliance.



## 2 Commissioning

### 2.1 Included in delivery

The delivery contains the following parts:

- Base device (one of the following models):
  - MRFsc 3501
  - MRFsc 3511
  - MRFsc 5501
- Operating manual

Check all parts for transport damage.

If you have any issues, please contact your dealer or Customer Service.

### 2.2 Setup conditions



#### **WARNING**

**Risk of fire due to moisture!**

**If live parts or the power cord get wet, this can cause a short circuit.**

- ➔ **The appliance is designed for use in enclosed spaces. Do not operate the appliance in open space or in damp areas or where there is spray.**

#### 2.2.1 Setup location



#### **WARNING**

**Leaking refrigerant and oil!**

**Fire. The refrigerant contained within the appliance is environmentally friendly, but flammable. The oil contained within the appliance is flammable. Escaping refrigerant and oil can ignite if they are of high enough concentration and are exposed to an external heat source.**

- ➔ **Do not damage the pipelines of the coolant circuit and the compressor.**

- Do not setup the appliance in direct sunlight, next to an oven, radiator or similar.
- The best place to set up the appliance is a dry and well ventilated room.
- If the appliance is set up in a very humid environment, condensation can form on the outside of the appliance.  
Always ensure sufficient airflow and ventilation in the setup location.

- The more refrigerant there is in the appliance, the larger the room must be in which the appliance is located. If rooms are too small, any leak may create a flammable mixture of gas and air. For every 8 g of refrigerant, the size of the installation space must be at least 1 m<sup>3</sup>. Specifications regarding the refrigerant contained within the appliance can be found on the type plate (MRFsc...) inside the appliance.
- The floor of the setup location must be horizontal and even.
- The setup location must be able to withstand the weight of the appliance plus the weight when stocked to maximum capacity (see chapter 5 TECHNICAL DATA).

### 2.2.2 Electrical connection



#### **WARNING**

##### **Danger of fire due to incorrect positioning!**

If the power supply cable or plug touches the back of the appliance, the vibration can damage the power supply cable or the plug resulting in a short circuit.

- ➔ **Make sure the power supply cable is not trapped under the appliance when you position the appliance.**
- ➔ **Install the appliance so that it does not touch any plugs or power cables.**
- ➔ **Do not connect any appliances to sockets in the area of the back of the appliance.**
- ➔ **Do not place and operate power strips/power distributors and other electronic devices (such as halogen transformers) at the back of the appliances.**

### 2.3 Transporting the appliance



#### **WARNING**

There is a risk of injury from pieces of broken glass (depending on model).

When transporting at an altitude of more than 1500 m, the glass panes of the door may break. This can result in sharp-edged fragments, which can cause serious injuries.

- ➔ **Adopt suitable protective measures.**

- On initial setup: Transport the appliance in its packaging.
- When transporting after initial setup (e.g. relocation): Transport the appliance unloaded.
- Transport the appliance upright.

- Use two people when transporting the appliance.

## 2.4 Unpacking the appliance

- 1 Check the appliance and the packaging for transport damage. Contact the supplier immediately if you suspect any damage. Do not connect the appliance to the power supply.
- 2 Remove all materials from the back or the side walls of the appliance that may prevent proper installation or prevent air flow and ventilation.
- 3 Take the power cable off of the rear of the appliance. Remove the cable retainer when you do so, otherwise there will be vibration noise.

## 2.5 Removing the transport lock



- 1 Pull tab (1) forwards.
- 2 Take off transport lock (2) in upwards direction. Base holder remains on the appliance.

## 2.6 Setting up the appliance



### CAUTION

Risk of injury and damage.

➔ Use 2 people to set up the appliance.

	<p><b>CAUTION</b> Risk of injury and damage. The door can strike against the wall and become damaged as a result. In the case of glass doors, the damaged glass can cause injuries.</p> <p>➔ Protect the door from striking against the wall. Attach a door stopper, e.g. felt stopper, to the wall.</p>
--	--

- 1 Connect all necessary components (e.g. power cable) to the back of the appliance and route to the side.

**NOTE**

*Cables can be damaged.*

- ➔ Do not crush the cable when pushing the appliance back.

- 2 Install the appliance either as free-standing or directly against a wall.

**2.7 Leveling out the appliance**

**NOTE**

*Appliance body can become deformed and door will not close.*

- ➔ Align appliance horizontally and vertically.
- ➔ Compensate for uneven floors using adjustable feet.

	<p><b>WARNING</b> Severe or fatal injuries. Incorrect height adjustment can cause the bottom part of the adjustable foot to come loose and the appliance to tip over.</p> <p>➔ Do not unscrew the adjustable foot too far.</p>
--	--

<p><b>Raising appliance</b></p>	<p><b>Lowering appliance</b></p>
<p>1 Turn adjustable foot clockwise.</p>	<p>1 Turn adjustable foot counter-clockwise.</p>

## 2.8 Setting up multiple appliances

### NOTE

*Risk of damage due to condensation between the side walls.*

- ➔ *Do not set up the appliance directly next to another appliance.*
- ➔ *Set up appliances with a space of 3 cm between appliances.*
- ➔ *At higher levels of humidity, increase the space between appliances.*

## 2.9 After setup

- 1 Pull off the protective film from the outside of the housing.
- 2 Clean the appliance (see section 3.2 CLEANING THE APPLIANCE).
- 3 If necessary: Disinfect the appliance.
- 4 Keep the invoice so you have the appliance and dealer information available if needed.

## 2.10 Disposal of packaging



### WARNING

**Danger of suffocation from packaging materials and films!**

- ➔ **Do not allow children to play with packaging materials.**

The packaging is made from recyclable materials:

- Corrugated card/cardboard
- Parts made of foamed polystyrene
- Films and bags from polyethylene
- Packing bands from polypropylene
- Wood frame nailed together with a polyethylene window\*

- 1 Take the packaging material to an official collection point.

## 2.11 Reversing the door

### Tools

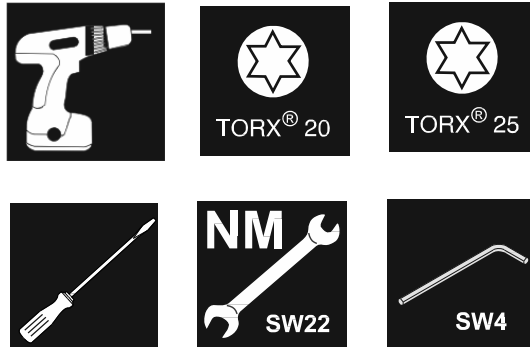

#### WARNING

Risk of injury if the door is not reversed correctly!

➔ The door may only be reversed by qualified personnel.



#### CAUTION

Risk of injury and material damage due to heavy door!

➔ Only perform the conversion if you can carry a weight of 25 kg.

➔ Always have someone help you carry out the conversion.

#### NOTE

*Live parts!*

*Damage to electrical components.*

➔ *Disconnect the power plug before reversing the door.*

1 Open the door.

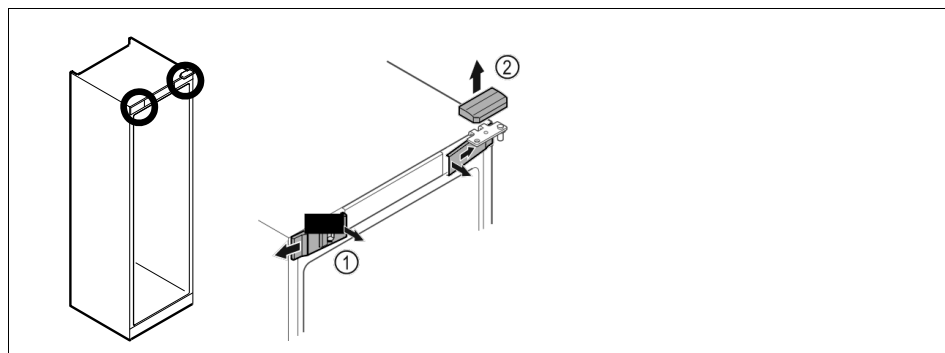

- 2 Unlatch the front covers (1) on the inside and remove them sideways.
  - 3 Lift off the upper cover (2).
- 

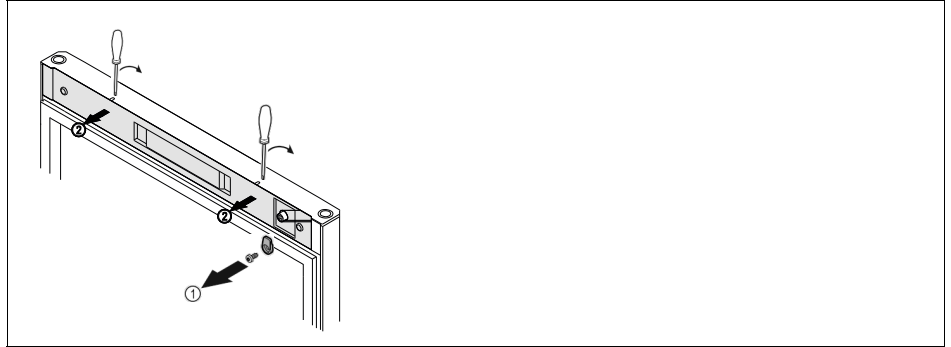

- 4 Unscrew the door latch (1).
  - 5 Unlatch the cover (2) with a small screwdriver and remove it.
- 

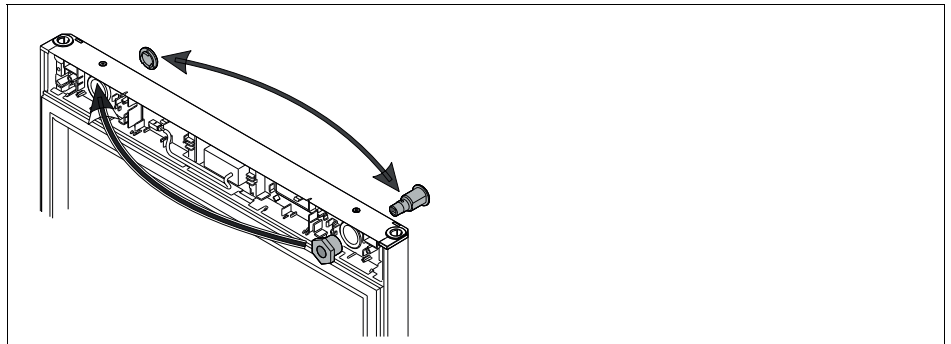

- 6 Put the lock and cover on the opposite side.
- 



**CAUTION**  
Risk of injury if the door tips out!  
➔ Hold the door.

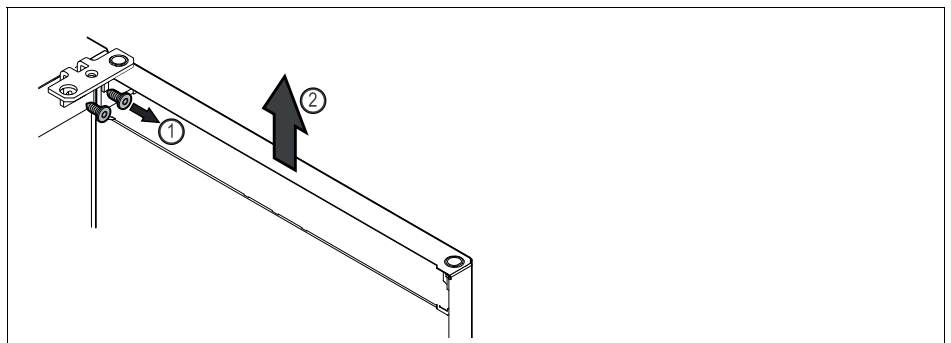

- 7 Unscrew the hinge (1).
  - 8 Lift the door with the hinge straight up by (2) roughly 200 mm and take it off.
  - 9 Carefully place the door on a soft surface.
- 

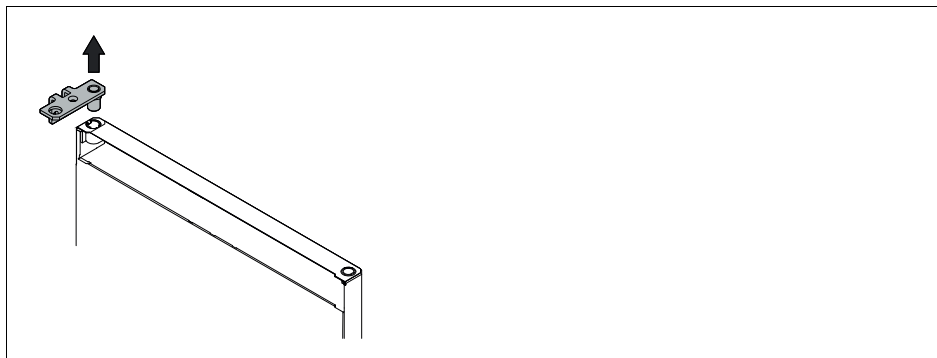

- 10 Pull out the hinge.
- 

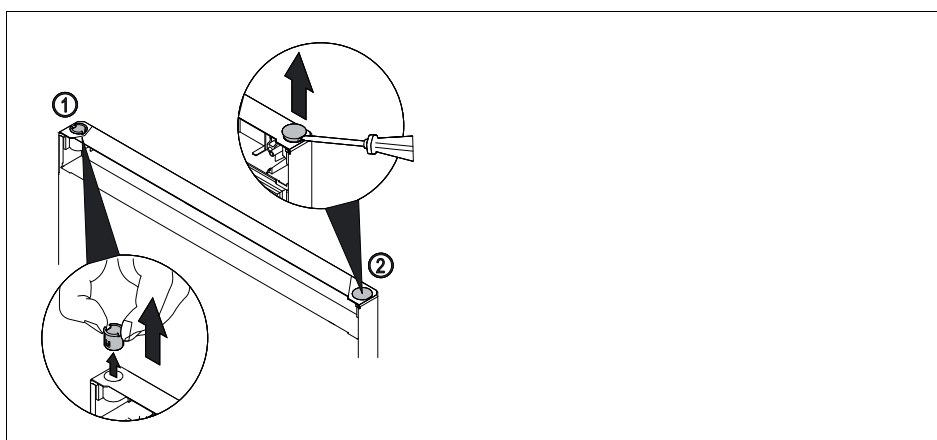

- 11 Pull out the hinge bushing (1) with your fingers.
  - 12 Carefully lift the cover plug (2) with a slotted screwdriver and pull it out.
-



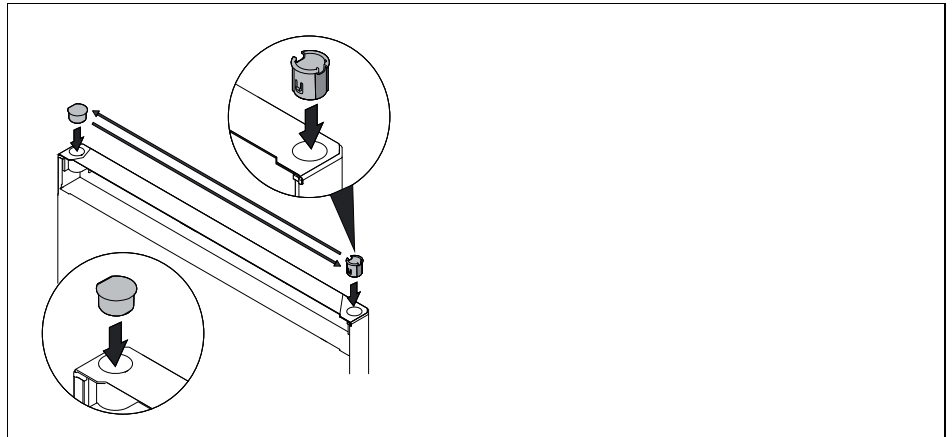

- 13 Insert hinge bushing and cover plug on the opposite side (the flattened sides face outwards).

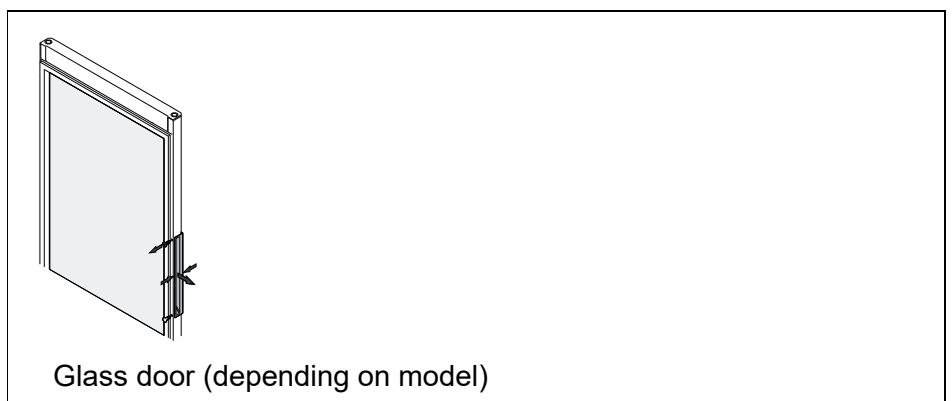
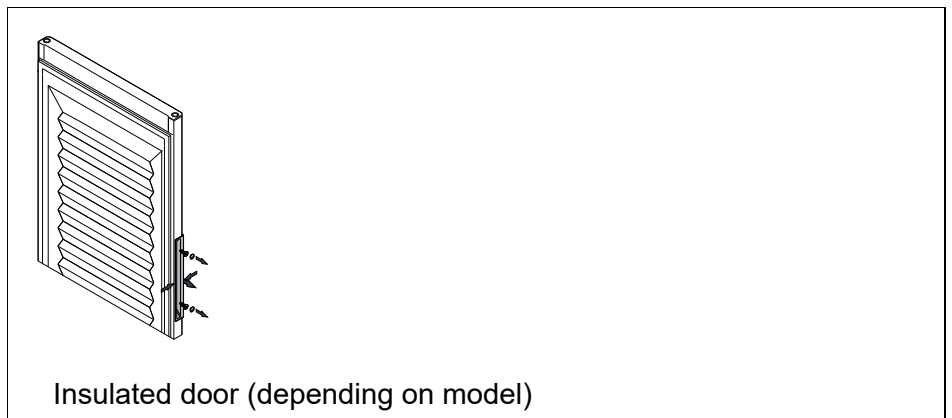

If the handle is difficult to detach from the door, slightly push the handle together when removing it.

- 14 Unscrew the handle.
- 

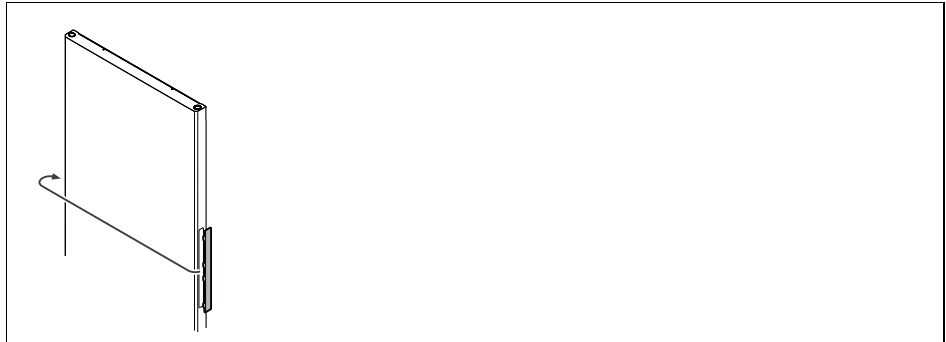

If the cover is difficult to detach, carefully lever it out using a tool such as a screwdriver.

- 15 Put the cover on the opposite side.
- 

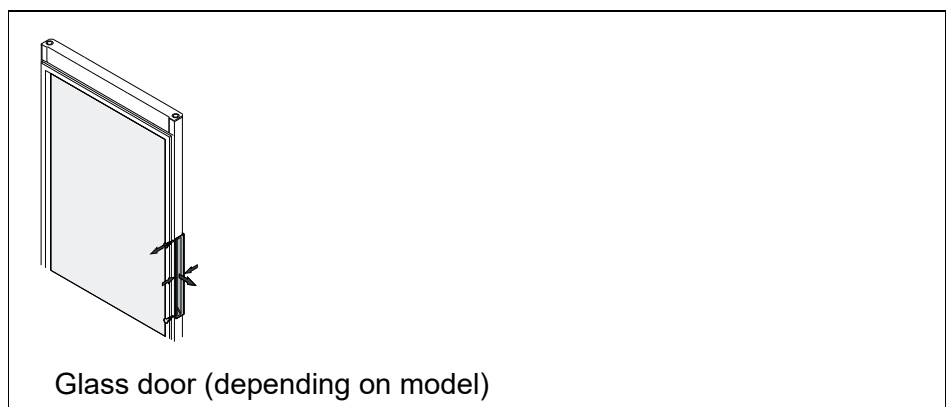
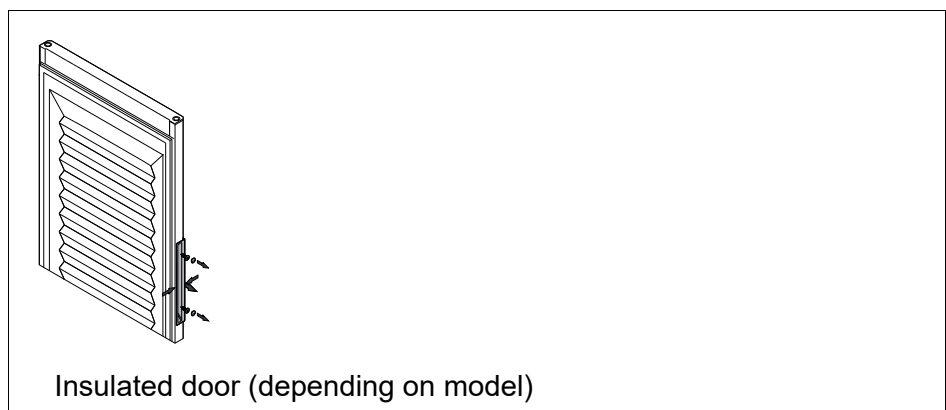

- 16 Screw the handle onto the opposite side.
-

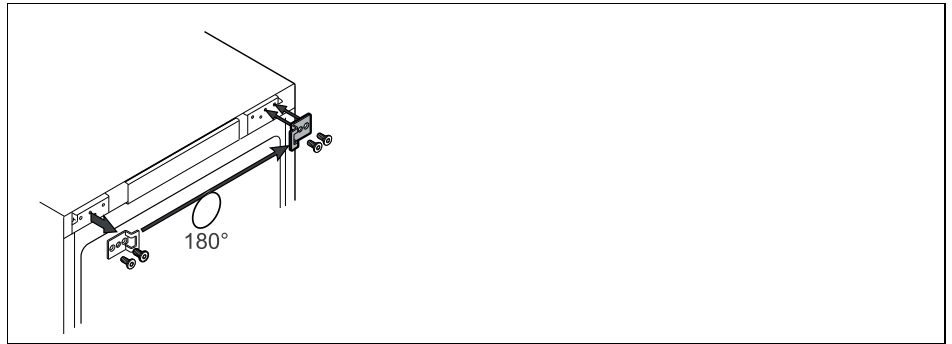

17 Put the closing bracket on the opposite side.



The holes are pre-marked and must be pierced with the self-tapping screws.

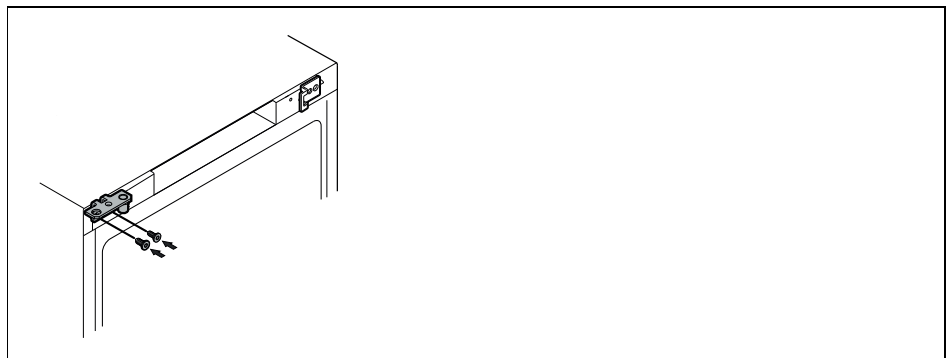

18 Move the hinge to the opposite side.



**CAUTION**

**Risk of injury and material damage if the door tips out!**

➔ **Tighten the bearing pins to the specified torque.**

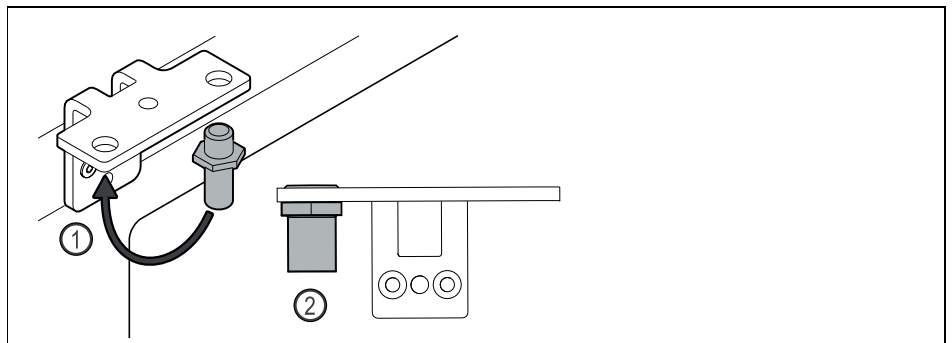

- 19 Put the pin back into the hinge (1).
- 20 Tighten the pin (2) to a torque of 12 Nm.
- 21 Unscrew the hinge again.

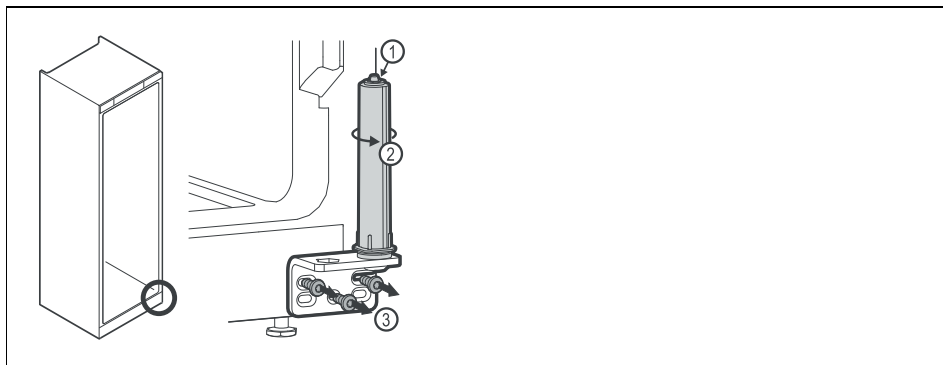
**CAUTION****Risk of injury due to tensioned spring!****➔ Do not disassemble the door closing system (1).**

- 22 Turn the closing system (2) until it clicks.  
The tension of the closing system is released.
- 23 Unscrew the hinge (3).

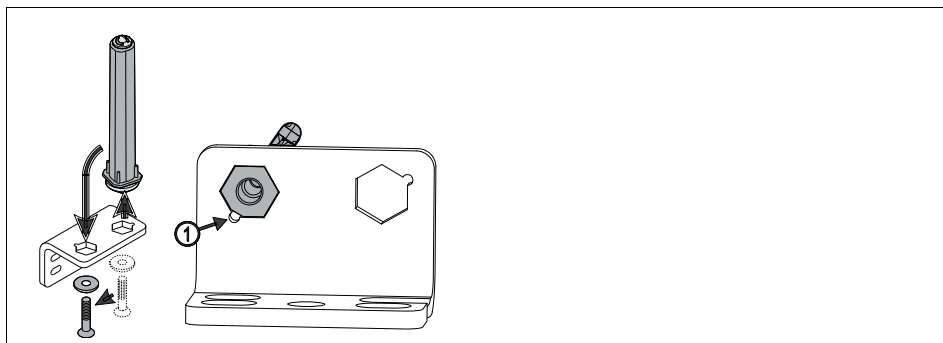

- 24 Put the door closing system in the hinge.
- 25 Make sure the pin chamfer (1) faces the round hole when you put it in.

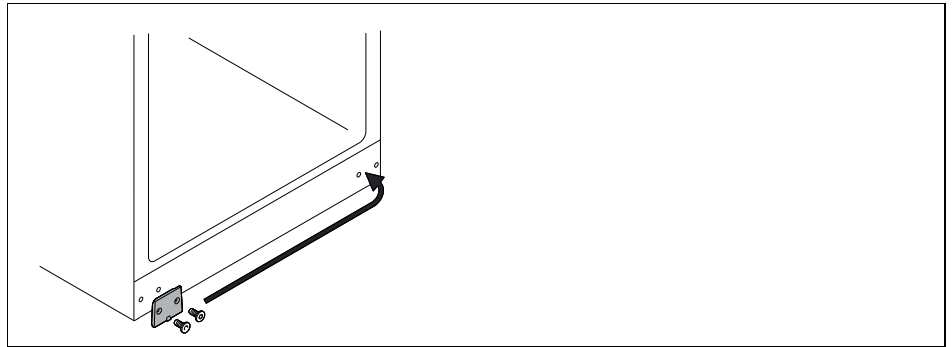

26 Put the cover plate on the opposite side.

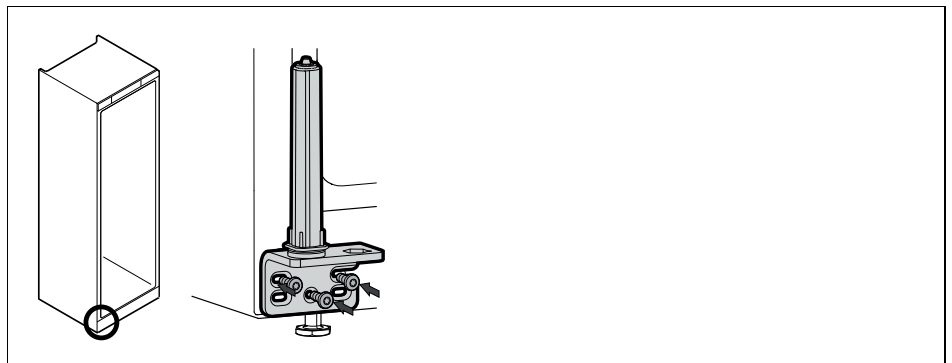

27 Screw the hinge onto the opposite side.



Correct alignment and tension are important for the closing system to work properly.

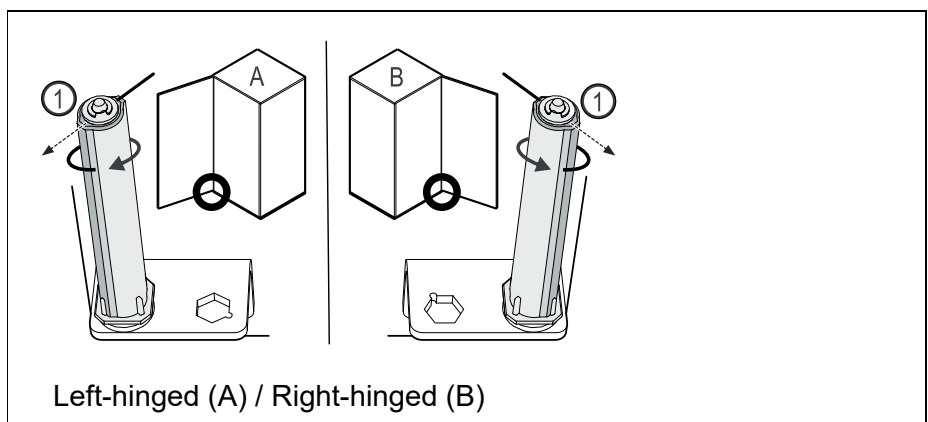

- 28 Turn the closing system against the resistance until the bar of the closing system (1) points outwards.  
The closing system automatically stays in this position.  
The closing system is now aligned and pretensioned.

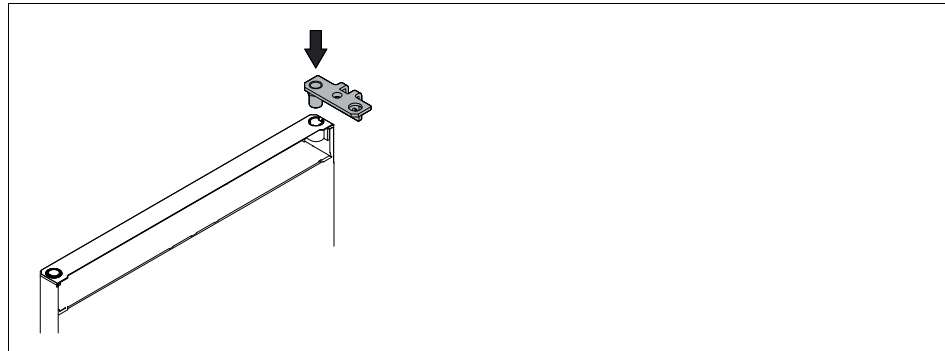

- 29 Put the hinge into the door.

**CAUTION**

Risk of injury if the door tips out!

➔ Hold the door.

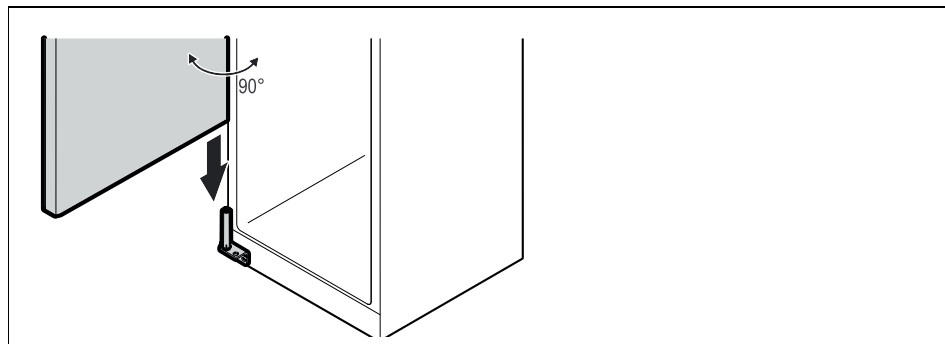

- 30 Together with a second person, lift the door from the ground.
- 31 Carefully put the door on the closing system with the door opened at a 90° angle.

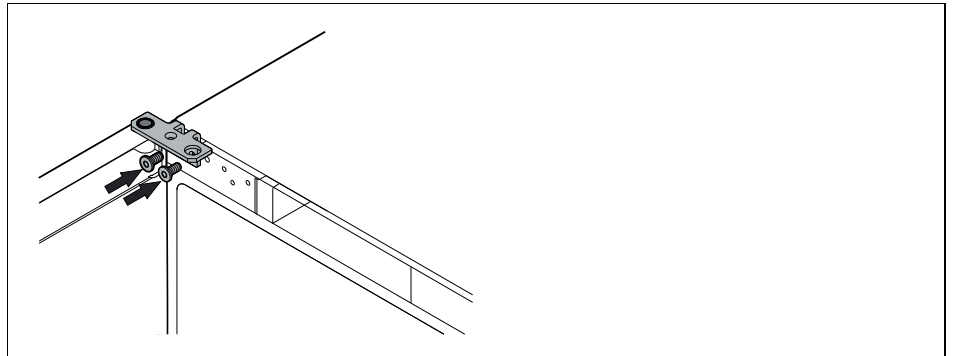

32 Screw on the hinge.

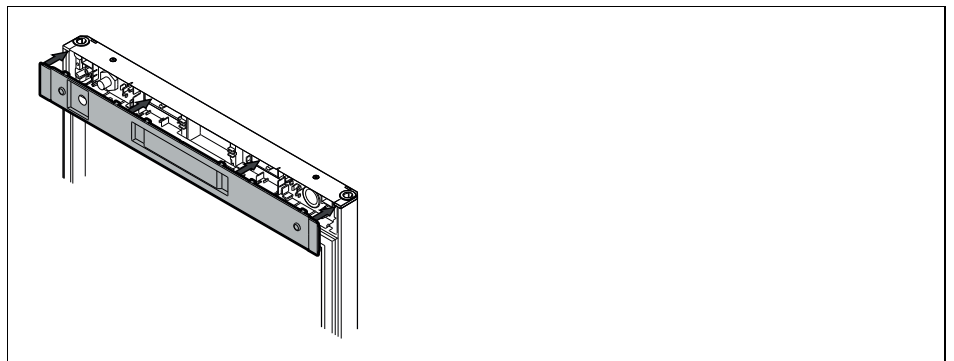

33 Put on the cover.

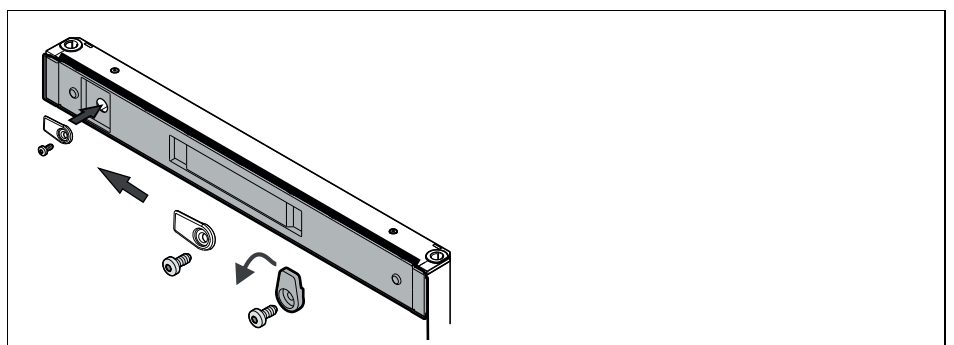

34 Screw on the door latch.



- 35 Open the door.

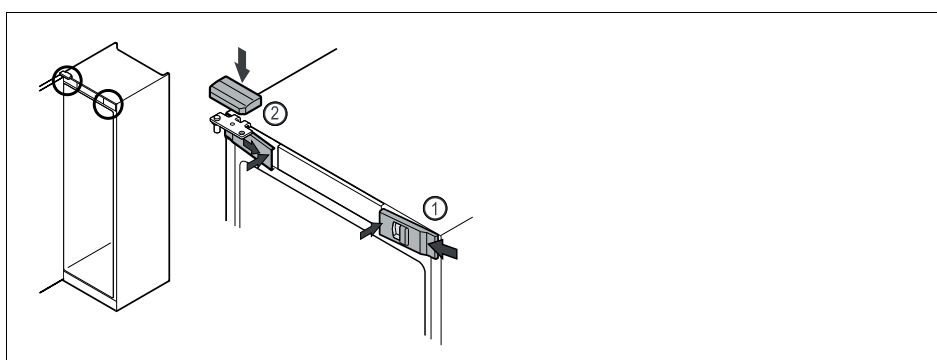

- 36 Hook in the front covers (1) on the side and snap them into place on the inside.
- 37 Snap on the top cover (2) from above.
- 38 Close the door.  
The door has now been reversed.



## 2.12 Aligning the door

If the door is not straight, you can adjust it on the lower hinge.

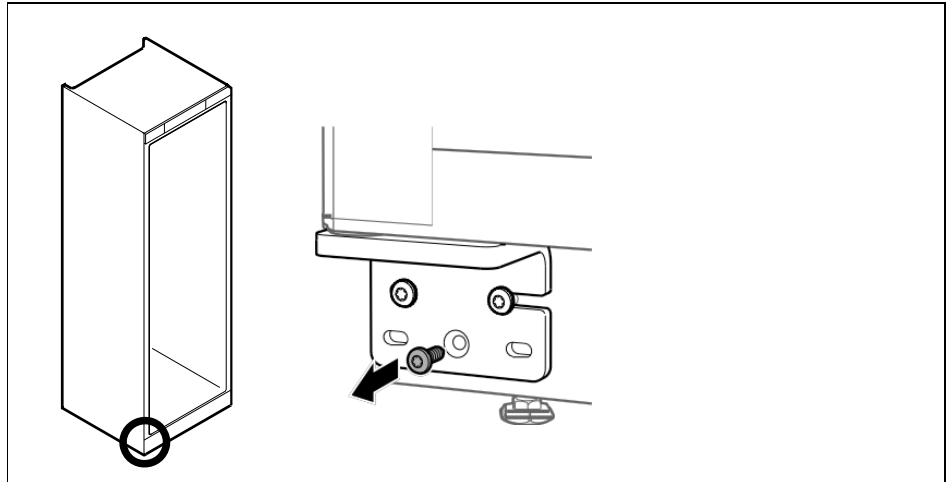

- 1 Remove the middle screw on the lower hinge.

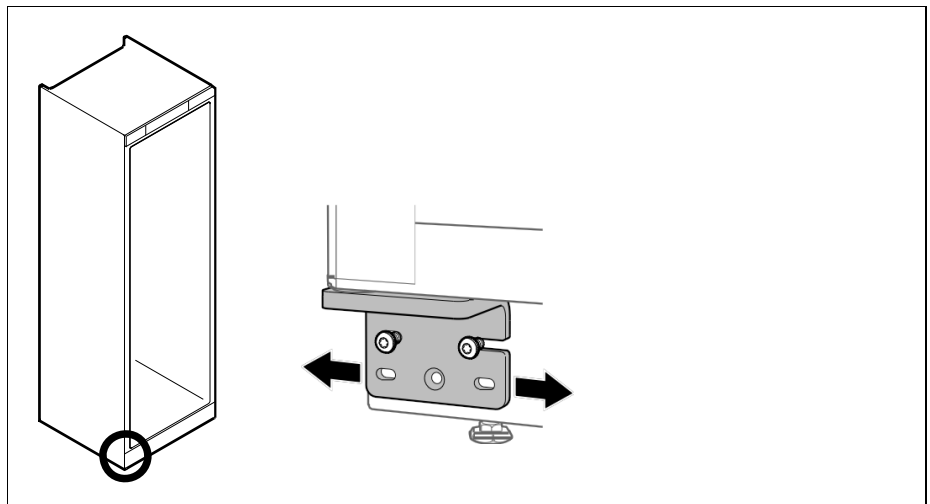

- 2 Slightly undo both screws and move the door with the hinge to the left or right.
- 3 Fully tighten the screws (the middle screw is no longer needed). The door is now straight.

## 2.13 Connecting the appliance



### WARNING

**Incorrect connection!  
Risk of fire.**

- ➔ Do not use an extension cord.
- ➔ Do not use a multipoint connector strip.

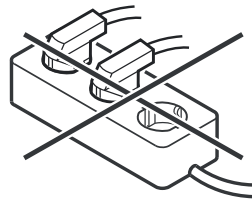

### NOTE

*Incorrect connection!  
Damage to the electronics.*

- ➔ Do not connect the appliance to a stand-alone inverter, e.g. solar power systems and petrol generators.

- 1 Make sure that the following requirements are fulfilled:
  - The appliance is operated using alternating current only.  
The permitted voltage and frequency are printed on the type plate (MRFsc...).
  - The socket is grounded and fused in accordance with regulations.
  - The tripping current for the fuse is between 10 A and 16 A.
  - The socket is easily accessible.
- 2 Check the electrical connection.
- 3 Connect the power plug to the power supply.

## 2.14 Switching on the appliance

- 1 Make sure that the following requirements are fulfilled:
  - The appliance is set up and aligned and there is a suitable power socket.
  - All adhesive strips, adhesive and protective films and transport locks are removed from inside and on the appliance.
- 2 Plug in the power plug.  
The appliance is switched on.

## 2.15 Items for refrigeration

Observe the following:

- Observe maximum load (section 5.3 DIMENSIONS, WEIGHT, EQUIPMENT).
- Items for refrigeration must not come into contact with the evaporator on the rear wall.
- Keep liquids in closed containers.
- Leave space when storing items for refrigeration to ensure adequate air circulation.

## 2.16 Safety lock

The lock in the appliance door is equipped with a safety mechanism.

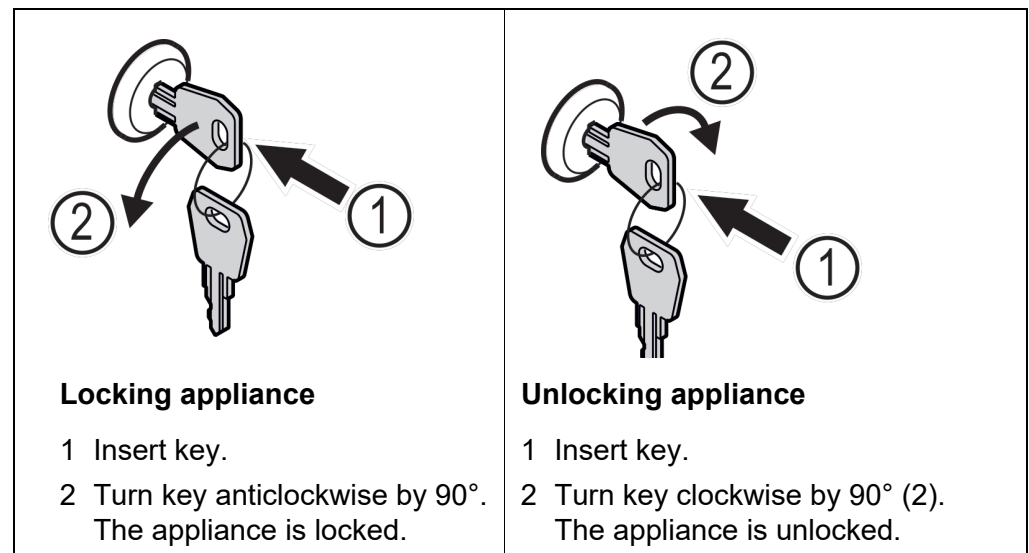

## 3 Maintenance, cleaning

### 3.1 Defrosting the appliance

**CAUTION**

**Appliance incorrectly defrosted!  
Injuries and damage.**

- ➔ **Do not use mechanical devices or other means to accelerate the defrosting process, other than those recommended by the manufacturer.**
- ➔ **Do not use any electrical heating or steam cleaning equipment, naked flames or defrosting sprays.**
- ➔ **Do not remove ice with sharp objects.**

Defrosting is performed automatically. The water from the defrosting process runs out via the drain opening and is evaporated.

To ensure the appliance remains energy efficient, we recommend defrosting it at regular intervals or if there is a large buildup of ice. The main factors causing ice to form inside your appliance are its location (e.g. high humidity), the settings on the appliance and user behavior.

#### Manual defrosting

- 1 Switch off appliance.
- 2 Disconnect power plug.
- 3 Store refrigerated items elsewhere.
- 4 Leave the appliance door open during defrosting process.
- 5 Soak up remaining defrost water with a cloth, clean the drain opening and the appliance.

### 3.2 Cleaning the appliance

#### 3.2.1 Preparing

**WARNING**

**Short-circuit hazard due to live parts!  
Electric shock or damage to the electronics.**

- ➔ **Switch off the appliance.**
- ➔ **Pull out mains plug or switch off fuse.**

**WARNING****Danger of fire****➔ Do not damage the refrigerant circuit.**

- 1 Empty the appliance.
- 2 Pull out the power plug.

**3.2.2 Cleaning the housing****NOTE***Improper cleaning!**Damage to the appliance.*

- ➔ Only use soft cleaning cloths and pH-neutral all-purpose cleaners.
- ➔ Do not use steel wool or sponges that scour or scratch.
- ➔ Do not use caustic or abrasive cleaning materials or those containing sand, chloride, or acids.

**CAUTION****Risk of injury or damage due to hot steam.****Hot steam can cause scalding/burns and damage to surfaces.****➔ Do not use steam cleaners.****NOTE***Risk of damage due to short circuit.*

- ➔ When cleaning the appliance, make sure no water gets into the electrical components.

- 1 Wipe the housing down with soft, clean cloth. If very dirty, use luke-warm water with a neutral cleaner. Glass surfaces can also be cleaned with glass cleaner.
- 2 Clean the condenser coil every year. If the condenser coil is not cleaned, this significantly reduces the efficiency of the appliance.

**3.2.3 Cleaning the interior****WARNING****Short-circuit hazard due to live parts!****Electric shock or damage to the electronics.**

- ➔ Switch off the appliance.
- ➔ Pull out mains plug or switch off fuse.

**CAUTION**

**Risk of injury or damage due to hot steam.  
Hot steam can cause scalding/burns and damage to surfaces.**

➔ **Do not use steam cleaners.**

**NOTE**

*Improper cleaning!*

*Damage to the appliance.*

- ➔ *Only use soft cleaning cloths and pH-neutral all-purpose cleaners.*
- ➔ *Do not use steel wool or sponges that scour or scratch.*
- ➔ *Do not use caustic or abrasive cleaning materials or those containing sand, chloride, or acids.*
- ➔ *Do not use any gritty or acidic cleaning agent or any chemical solvent.*

- 1 Open the door.
- 2 Empty the appliance.
- 3 Clean the interior and equipment parts with lukewarm water and a little dish detergent.

**Defrost water drain**

- 1 Remove deposits using a thin object (e.g. a cotton bud).



Do not damage or remove the type plate on the inside of the appliance. The type plate is important for after sales service.

**3.2.4 After cleaning**

- 1 Wipe the appliance and equipment parts dry.
- 2 Connect and switch on appliance.
- 3 When the temperature is sufficiently cold:  
Place in items for refrigeration.
- 4 Clean regularly.
- 5 Clean and dust appliances with a heat exchanger (metal grill on rear of appliance) once per year.

### 3.3 Shutting down

- 1 Empty the appliance.
- 2 Switch off appliance.
- 3 Pull out the power plug.
- 4 Clean the appliance (see section 3.2 CLEANING THE APPLIANCE).
- 5 Leave the door open so that no bad odors form.

**NOTE**

*Damage to the appliance and malfunctions!*

- ➔ *After shutting down, only store the appliance at the permitted room temperature (see section 5 TECHNICAL DATA) .*

## 4 What to do if...

<b>The appliance is not working</b>	<b>Cause</b>	<b>Remedy</b>
	The appliance is not switched on.	Switch on the appliance.
	The power plug is not properly inserted in the socket.	Check the power plug.
	There is a problem with the wall socket breaker.	Check the breaker.
	Power failure	Keep the appliance closed.
<b>The temperature is not cold enough</b>	<b>Cause</b>	<b>Remedy</b>
	The appliance door is not closed properly.	Close the appliance door.
	Ventilation is not sufficient.	Unclog the ventilation grill and clean it.
	The ambient temperature is too high.	Observe the suitable ambient conditions: (see chapter 5 TECHNICAL DATA)
	The appliance was opened too many times or for too long.	Wait to see if the required temperature is achieved once again on its own. If not, contact Customer Service.
	The temperature is set incorrectly.	Set a colder temperature and check after 24 hours.
	The appliance is too close to a heat source (stove, heater etc).	Move either the appliance or the heat source.



## 5 Technical data

### 5.1 General data

<b>Ambient conditions</b>	Site altitude	Instruments with a glass door (MRFsc 3511): max. 1500 m above sea level Instruments without a glass door: max. 2000 m above sea level
	Operation	+ 10 °C ... + 40 °C Operation only in buildings
	Storage	- 10 °C ... + 50 °C

#### NOTE

*The minimum permitted room temperature at the setup location is +10 °C. Slight condensation may form on the glass door on the side walls if the boundary conditions are exceeded.*

**Climate class** 5

<b>Sound emission of the appliance</b>	Emission sound pressure level during operation	A (< 70 dB(A) (sound power rel 1 pW)
	Guidelines and norms used	EMC EC directive 2014/30/EC EN 61326-1
		Instrument safety EC directive 2014/35/EC EN 61010-1
	RoHS	EC directive 2011/65/EC EN IEC 63000

### 5.2 Electrical data

<b>Power supply</b>	Nominal voltage	220 - 240 VAC
	Supply frequency	50 Hz according to DIN IEC 60038
	Protective class	I
	Internal instrument safety	6,3 A delay fuse, for TR-1 control unit and compressor. The fuse is on the operating front of the control unit.



**WARNING**

If an unsuitable fuse is used, there is the risk of cable fire. The original fuse may only be replaced with a fuse of the same type.

	TS 700/4-i	TS 700-G/4-i	TS 1010-i
Max. electric power consumption	380W	380W	380W
Max. electric current	2.0 A	2.0 A	2.0 A

Consumers connected to the sockets of the control unit are not taken into account for these specifications.

**5.3 Dimensions, weight, equipment**

	TS 700/4-i	TS 700-G/4-i	TS 1010-i
<b>Volume [l]</b>	317	337	534

**Outer dimensions [mm]**

Height	1684	1684	1684
Width	597	597	747
Depth	654	654	769

**Inner dimensions [mm]**

Height	1459	1459	1459
Width	475	475	625
Depth	423	423	539

**Weight [kg]**

Gross (incl. packing material)	64	78	82
Net	53	69	69

**Gratings**

Number	4	4	4
Maximum load	45 kg	45 kg	60 kg

**Refrigerant gas**

Quantity (g)	60	60	70
--------------	----	----	----

## 6 Disposal

Handle and dispose of all waste in compliance with local laws and regulations.

### **EU only: Correct disposal of this product — WEEE Directive on waste electrical and electronic equipment**

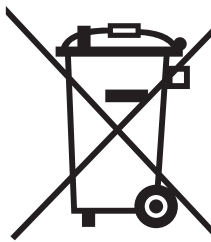

This marking on the product, accessories or literature indicates that the product should not be disposed of with other waste at the end of its working life.

To prevent possible harm to the environment or human health from uncontrolled waste disposal, please separate these items from other types of waste and recycle them responsibly to promote the sustainable reuse of material resources.



Waste from electrical and electronic equipment can be returned to the producer or distributor.





# Xylem |'zīləm|

- 1) The tissue in plants that brings water upward from the roots;
- 2) a leading global water technology company.

We're a global team unified in a common purpose: creating advanced technology solutions to the world's water challenges. Developing new technologies that will improve the way water is used, conserved, and re-used in the future is central to our work. Our products and services move, treat, analyze, monitor and return water to the environment, in public utility, industrial, residential and commercial building services settings. Xylem also provides a leading portfolio of smart metering, network technologies and advanced analytics solutions for water, electric and gas utilities. In more than 150 countries, we have strong, long-standing relationships with customers who know us for our powerful combination of leading product brands and applications expertise with a strong focus on developing comprehensive, sustainable solutions.

**For more information on how Xylem can help you, go to [www.xylem.com](http://www.xylem.com).**



## **Service and Returns:**

Xylem Analytics Germany  
Sales GmbH & Co. KG  
WTW  
Am Achalaich 11  
82362 Weilheim  
Germany

Tel.: +49 881 183-325  
Fax: +49 881 183-414  
E-Mail [wtw.rma@xylem.com](mailto:wtw.rma@xylem.com)  
Internet: [www.xylemanalytics.com](http://www.xylemanalytics.com)



Xylem Analytics Germany GmbH  
Am Achalaich 11  
82362 Weilheim  
Germany

