

SensoLyt 700



SensoLyt 700 SW

SensoLyt[®] 700

PH/ORP ARMATURE WITH IMPEDANCE CONVERTER AND TEMPERATURE SENSOR



a xylem brand

Copyright © 2020 Xylem Analytics Germany GmbH
Printed in Germany..

Sensolyt® 700 - Contents

1	Overview	4
1.1	Structure of the Sensolyt® 700 pH/ORP armature	4
1.2	Recommended fields of application	4
2	Safety	5
2.1	General information on safety	5
2.2	Authorized use	6
2.3	User qualifications	6
2.4	General safety instructions	6
3	Commissioning	8
3.1	Scope of delivery	8
3.2	Installation	8
3.3	Commissioning / Getting the instrument ready for measuring	9
4	Measuring / Operation	12
4.1	Calibration	12
4.2	Measuring	12
5	Maintenance and changing the electrode	13
5.1	General maintenance instructions	13
5.2	Replacing the combination electrode	13
5.3	Cleaning	17
5.4	Disposal	17
6	Replacement parts and accessories	18
6.1	Combination electrodes	18
6.2	General accessories	18
7	What to do if...	19
8	Technical data	20
8.1	Measurement characteristics	20
8.2	Application characteristics	20
8.3	General data	22
8.4	Electrical data	24

1 Overview

1.1 Structure of the SensoLyt® 700 pH/ORP armature

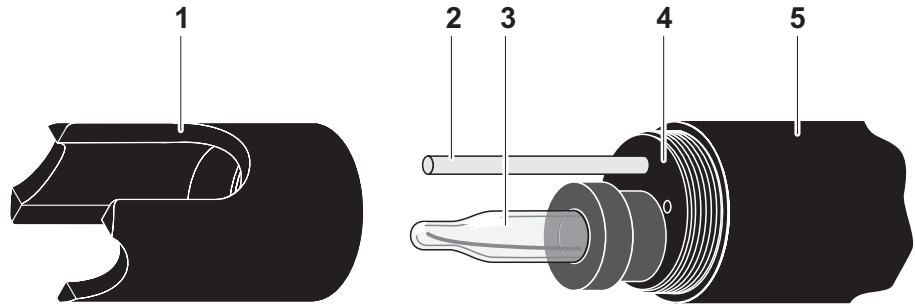

Fig. 1-1 Structure of the pH/ORP armature (example, SensoLyt® 700)

1	Protective hood
2	Temperature sensor
3	Electrode (not contained in the scope of delivery)
4	Electrode receptacle
5	Armature shaft



Note

The pH combination electrodes that can be used are available as accessories (see chapter 6 REPLACEMENT PARTS AND ACCESSORIES).

Impedance converter

An impedance converter integrated in the armature shaft converts the high-impedance measurement signal of the electrode into a low-impedance signal. This ensures an interference-free signal transmission even over greater distances.

Glass breakage monitoring

The sensor is equipped with a SensCheck function for monitoring glass breakage.

1.2 Recommended fields of application

In conjunction with the SensoLyt® SEA, SensoLyt® DWA and SensoLyt® ECA pH combination electrodes as well as the SensoLyt® PtA ORP combination electrode, the SensoLyt® 700 pH/ORP armature is suitable for stationary pH or ORP measurement in the following fields:

- SensoLyt 700**
- SensoLyt 700 SW**

Stationary measurements in water/wastewater applications.

Stationary measurements in seawater and brackish water, aquaculture.

2 Safety

2.1 General information on safety

These safety instructions contain all instructions that have to be followed for a safe operation of the Sensolyt® 700 pH/ORP armature. Before starting any work with the Sensolyt® 700, carefully read the safety instructions and strictly follow all protective measures mentioned.

Always keep this operating manual in the vicinity of the armature.

General safety instructions

Safety instructions in this operating manual can be recognized by the warning symbol (triangle) in the left column. The signal word (e. g. "Caution") indicates the level of the danger:



Warning

indicates instructions that must be followed precisely in order to prevent serious dangers to persons.



Caution

indicates instructions that must be followed precisely in order to avoid slight injuries or damage to the instrument or the environment.

Other labels



Note

indicates notes that draw your attention to special features.



Note

indicates cross-references to other documents, e.g. operating manuals.

2.2 Authorized use

The authorized use of the SensoLyt® 700 consists of the stationary measurement of pH or ORP and temperature in conjunction with a pH or ORP combination electrode. The technical specifications according to chapter 8 TECHNICAL DATA must be observed. Only operation according to the instructions given in this operating manual is considered to be authorized.

Any other use is considered to be **unauthorized**. Unauthorized use invalidates any claims with regard to the guarantee.

2.3 User qualifications

Calibrating the SensoLyt® 700 requires the handling of chemicals. Thus, we assume that the relevant personnel are familiar with the necessary precautions to take when dealing with chemicals as a result of their professional training and experience.

2.4 General safety instructions

The armature left the factory in a safe and secure technical condition.

The failure-free function and operational safety of the armature is only guaranteed if the generally applicable safety measures and the special safety instructions in this operating manual are followed during its use.

The smooth functioning and operational safety of the armature can only be guaranteed under the environmental conditions that are specified in chapter 8 TECHNICAL DATA.

The specified temperature (chapter 8 TECHNICAL DATA) must be maintained during the application and transport of the armature. Protect the armature, particularly against frost or overheating.

Function and operational safety

Safe operation

If safe operation is no longer possible, the armature must be taken out of operation and secured against inadvertent operation.

Safe operation is no longer possible if the armature:

- has been damaged in transport
- has been stored under adverse conditions for a lengthy period of time
- is visibly damaged
- no longer operates as described in this manual.

If you are in any doubt, contact the supplier of your armature.

Obligations of the operator

The operator of the armature must ensure that the following rules and regulations are followed when dealing with hazardous substances:

- EEC directives for protective labor legislation
- National protective labor legislation
- Safety regulations
- Safety data sheets of the chemical manufacturer.

**Caution**

All changes of the Sensolyt® 700 that exceed the work described in this operating manual are not allowed. Repair work may only be carried out by WTW Weilheim.

3 Commissioning

3.1 Scope of delivery

- SensoLyt® 700 pH/ORP armature
The armature is equipped with a protective hood and protection caps
- Operating manual.

3.2 Installation



Caution

The SensoLyt® 700 pH/ORP armature may only be submersed in conjunction with a mounted combination electrode. When exchanging the electrode, no moisture may get into the armature, as otherwise the armature will be destroyed. Which electrodes can be used together with the SensoLyt® 700 pH/ORP armature is given in section 6.1 COMBINATION ELECTRODES.

Connection to the measuring transmitter

The connection cable of the SensoLyt® 700 is ready to be connected to the terminal strip of a measuring transmitter with high-impedance pH/ORP input. For all further information please refer to the operating manual of the measuring transmitter. The assignment of the cable wires of the SensoLyt® 700 can be found in the chapter 8 TECHNICAL DATA of this operating manual.



Note

Do not suspend the sensor on the sensor connection cable. Use an armature or electrode holder. Information on this and other accessories is given in the WTW catalog and on the Internet.

3.3 Commissioning / Getting the instrument ready for measuring



Note

A KCl-filled plastic cap is mounted on the tip of the sensor to keep the electrode active during storage (or during longer pauses in measuring). The cap must be removed for measuring.

Mounting the combination electrode

- 1 | Unscrew the protective hood from the armature.

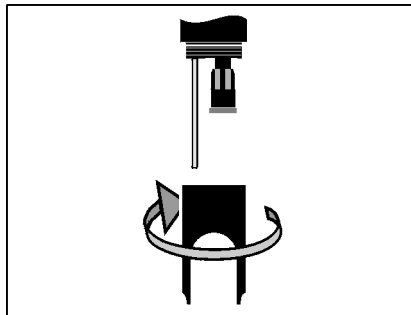

- 2 | Pull off the blind plug from the plug head socket of the armature.

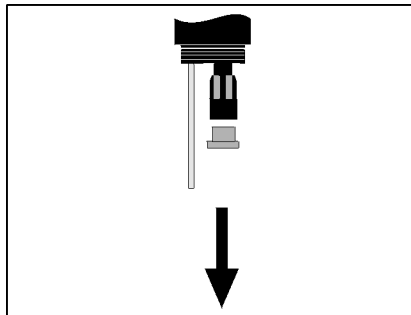

- 3 | Screw off the protective cap of the plug head connector of the electrode.

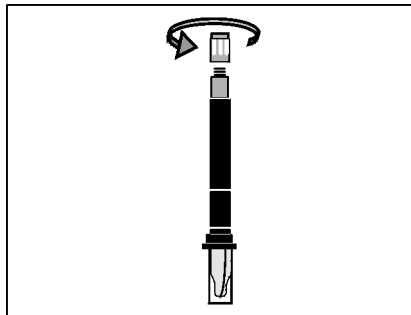

- 4 | Screw the electrode into the plug head socket of the armature.

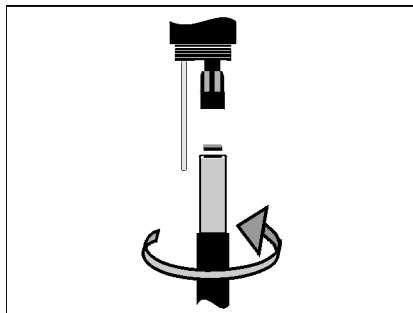

- 5 | Push the unit into the armature up to the stop.

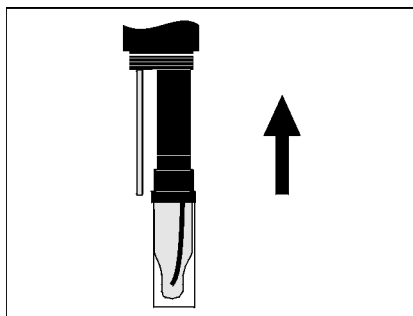

Caution

Push the connected electrode into the armature right up to the stop so that the connection is watertight.

- 6 | Pull the KCl-filled plastic cap off the electrode for measuring.

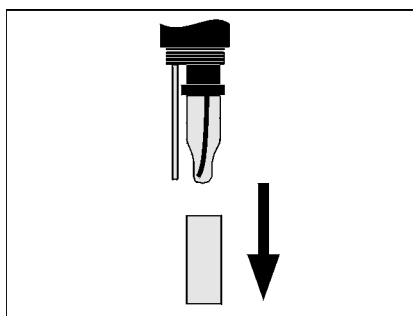

- 7 | Screw the protective hood onto the armature.

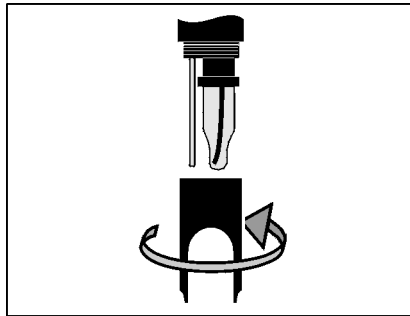

- 8 | Make the settings for the electrode on the measuring transmitter. Subsequently, calibrate the measuring system (see section 4.1 CALIBRATION).

4 Measuring / Operation



Note

Calibrate the measuring system after the initial commissioning and at regular intervals (depending on the application).

4.1 Calibration

Why calibrate?

During the operation of a pH electrode, the slope and asymmetry of the electrode changes with time. The calibration procedure determines the current slope and asymmetry of the electrode.

When to calibrate?

Calibrate before measuring and at regular intervals (depending on the application).

Calibration procedures

The available calibration procedures depend on the measuring transmitter used. The individual steps for the calibration are comprehensively described in the operating manual of the measuring transmitter.

4.2 Measuring



Warning

**Contact with the sample can lead to danger to the user!
Depending on the type of sample, suitable protective measures must be taken (protective clothing, protective goggles, etc.).**

Please pay attention to:

- the minimum immersion depth of the armature (> 40 mm)
- the measuring range of the electrode used (see operating manual of the electrode).

5 Maintenance and changing the electrode

5.1 General maintenance instructions

The Sensolyt® 700 pH/ORP armature works maintenance-free. Please read the maintenance of the electrode in the relevant operating manual of the electrode.

5.2 Replacing the combination electrode



Warning

Contact with the sample can lead to danger to the user! Depending on the type of sample, suitable protective measures must be taken (protective clothing, protective goggles, etc.).



Caution

If the glass of the pH electrode breaks, there is a danger of cuts from the splinters of glass!

If it is necessary to replace an electrode, proceed as follows:

- 1 Unscrew the protective hood from the armature.

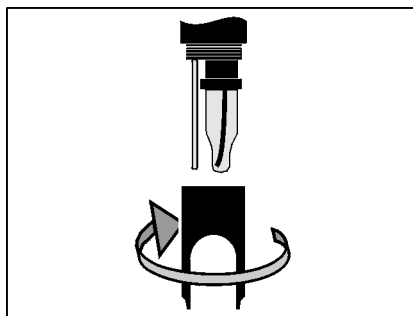

- 2 Use the protective hood as a tool to lever out the electrode.

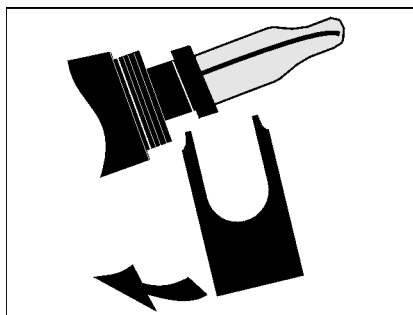

- 3 Carefully pull out the electrode until the plug head screwed fitting can be seen.

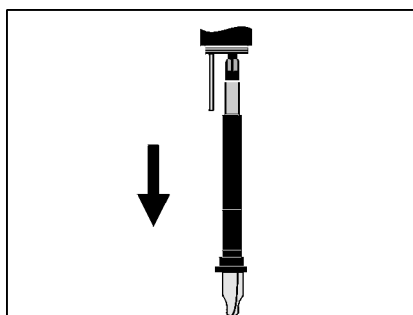

- 4 Unscrew the combination electrode from the plug head socket (for disposal, see section 5.4).

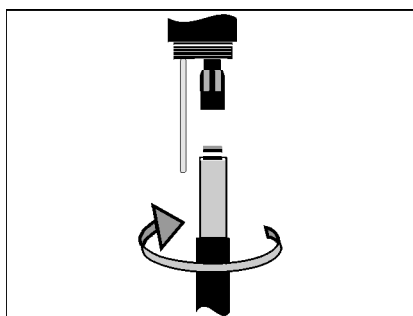

5 | Screw in a new electrode.

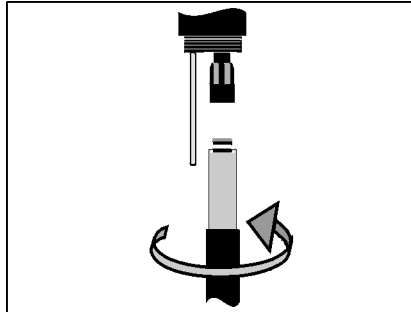

6 | Push the unit into the armature up to the stop.

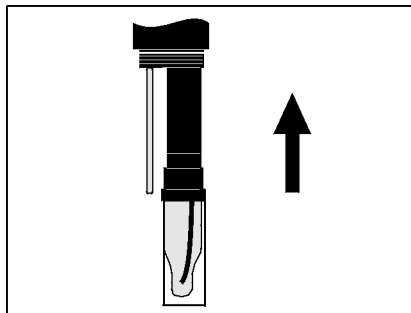

Caution

Push the connected electrode into the armature right up to the stop so that the connection is watertight.

7 | Pull the KCl-filled plastic cap off the electrode for measuring.

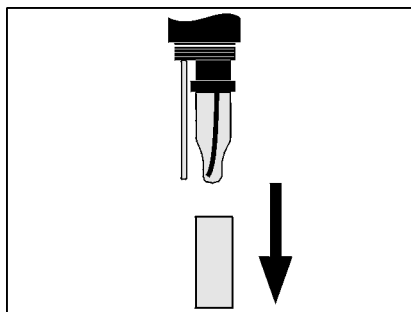

8 | Screw the protective hood onto the armature.

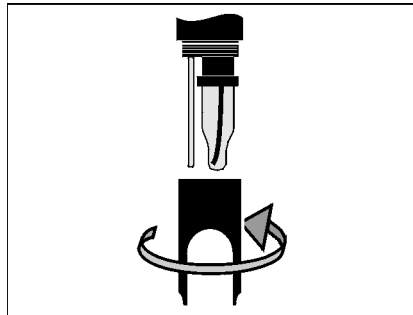

- 9 | Calibrate the measuring system (see section 4.1 CALIBRATION).

5.3 Cleaning

For normal operation (e.g. municipal wastewater), exterior cleaning and calibration are strongly recommended:

- in the case of pollution (according to visual check)
- if there is a suspicion of erroneous measured values
- if the measured value lies outside the range of precision required by the user during the function check.

Exterior cleaning

Contamination	Cleaning agents
For sludge and loosely adhering dirt, or biological deposits	Soft cloth or soft sponge, warm tapwater with detergent
Salt and / or lime deposits	Acetic acid (volume percentage = 20 %), soft cloth or soft sponge



Note

Please also observe the instructions on cleaning the electrode in the respective operating manual.

5.4 Disposal

Armature

We recommend disposing of the armature as electronic refuse.

Combination electrodes

If no official regulations apply to the contrary, used and defective electrodes can be treated as household waste.

6 Replacement parts and accessories

6.1 Combination electrodes



Caution

The pressure resistance of the operable pH/ORP armature can be restricted by the pressure resistance of the electrode (see chapter 8 TECHNICAL DATA). When selecting the electrode please make sure it is suitable for the pressure range and temperature range planned.

	Model	Order no.
pH combination electrodes	SensoLyt® SEA	109 115
	SensoLyt® DWA	109 119
	SensoLyt® ECA	109 117
	SensoLyt® SEA-HP	109 118
ORP combination electrode	SensoLyt® PtA	109 125

6.2 General accessories

	Buffer (bottles of 1 liter)	pH value	Order no.
Technical buffer solutions for pH calibration	TEP 4	4,01	108 700
	TEP 7	7,0	108 702
	TEP 10	10,0	108 704
Protective hood	Model	Order no.	
	SensoLyt® 700 SK	109 194	



Note

Information on further accessories is given in the WTW catalog and on the Internet.

7 What to do if...

Measurement delivers no or wrong measured values

Cause	Remedy
– Armature not connected	– Check connection to meter
– Electrode not connected or defective	– Check electrode and electrode connection
– Watering cap still on the electrode	– Pull off watering cap and calibrate
– No or wrong calibration performed	– Calibrate
– Electrode contaminated	– Clean electrode
– Liquid has penetrated the armature	– Armature defective, return to WTW
– Instrument setting incorrect	– Correct instrument setting

System cannot be calibrated

Cause	Remedy
– Slope of the electrode too low	– Replace electrode
– Asymmetry of the electrode too high	– Replace electrode
– Armature is operated with ORP electrode	– Use pH electrode

8 Technical data

8.1 Measurement characteristics

Measuring principle Potentiometric measurement using a combination electrode. Signal amplifier integrated in the sensor for low impedance signal transmission

Measuring range Depending on the built-in electrode

Temperature measurement	Sensor accuracy	± 0.3 K
	Response time	t ₉₉ (99 % of the final value display after) < 15 s

8.2 Application characteristics

Temperature range	Measuring medium	0 °C ... + 60 °C (32 ... 140 °F)
	Storage/transport	- 5 °C ... + 65 °C (23 ... 149 °F)

Allowed pH range of the test sample 4 ... 12

Pressure resistance Max. allowed overpressure (sensor including connection cable):

with installed combination electrode, SensoLyt® SEA, DWA, PtA	10 ⁶ Pa (10 bar) *
with installed combination electrode, SensoLyt® ECA	6 x10 ⁵ Pa (6 bar) *
with installed combination electrode, SensoLyt® SEA-HP	10 ⁶ Pa (10 bar) **

* temperature dependent (see safety instruction below)

** in the entire temperature range

The SensoLyt® 700 meets the requirements according to article 3(3) of the directive, 97/23/EC ("pressure equipment directive").

Immersion depth	with installed combination electrode, SensoLyt® SEA, DWA, PtA	min. 40 mm; max. 100 m * or to cable end
	with installed combination electrode, SensoLyt® ECA	min. 40 mm; max. 60 m * or to cable end
	with installed combination electrode, SensoLyt® SEA-HP	min. 40 mm; max. 100 m ** or to cable end

* temperature dependent (see safety instruction below)
 ** in the entire temperature range



Caution

The pressure resistance of the operable pH/ORP armature can be reduced by the pressure resistance of the combination electrode. When selecting the combination electrode make sure it is suitable for the intended pressure and temperature range.

Type of protection	Armature with integrated electrode including connection cable	IP 68, 10 bar (10 ⁶ Pa)
	Plug connector	IP 65

Operating position Any

Fields of application	SensoLyt 700	Stationary measurements in water/wastewater applications
	SensoLyt 700 SW	Stationary measurements in seawater and brackish water, aquaculture

Automatic sensor monitoring (SensCheck function) Function for glass breakage monitoring of the pH electrode by the measuring transmitter

8.3 General data

Dimensions

SensoLyt 700:

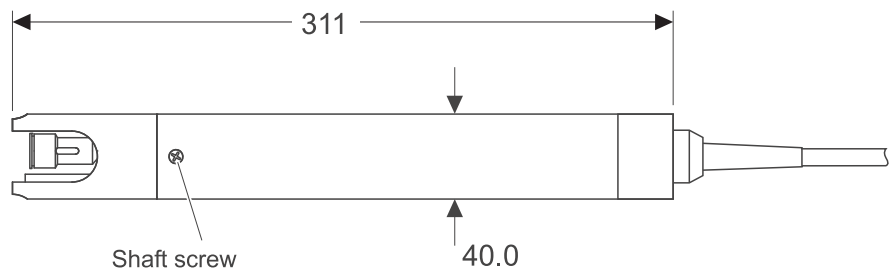

SensoLyt 700 SW:

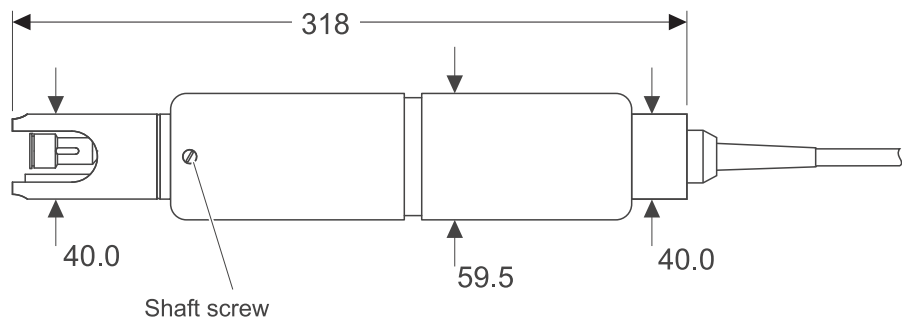

Weight (without sensor connection cable and combination electrode)

SensoLyt 700	approx. 320 g
SensoLyt 700 SW	approx. 880 g

Electrodes that can be integrated

pH combination electrodes	SensoLyt® SEA, SEA-HP, DWA, ECA
ORP electrodes	SensoLyt® PtA

Connection technique

Connection cable permanently mounted on the sensor.
 Connection to the measuring transmitter via 7-pole screw plug.

Material	Shaft	POM
	Shaft screw:	
	– Sensolyt 700	V4A stainless steel 1.4571
	– Sensolyt 700 SW	Titan Grade 2
	Protective hood	PVC
	Electrode receptacle	POM
	Temperature sensor:	
	– Sensolyt 700	V4A stainless steel 1.4571
	– Sensolyt 700 SW	V4A stainless steel 1.4571, KTL-coated
	Closing head	POM
	Protection ring	POM
Connection cable	Cable gland:	
	– Sensolyt 700	V4A stainless steel 1.4571
	– Sensolyt 700 SW	Titan Grade 2
	Cable sheath	PUR
	Length:	
– Sensolyt 700	7 m (special lengths on request)	
– Sensolyt 700 SW	15 m	
Diameter	8.6 mm	
Smallest allowed bend radius	Permanent bend: 130 mm Short time bend: 80 mm	
Instrument safety	Applicable norms	<ul style="list-style-type: none"> – EN 61010-1 – UL 3111-1 – CAN/CSA C22.2 No. 1010.1
Electromagnetic compatibility	EN 61326-1, FCC class A	

8.4 Electrical data

Pin assignment	Pin	Assignment	Voltage	Max. current
	1	Ua (output signal)	---	---
	2	0 V	---	---
	3	Ub+	+ 10 V	< 1 mA
	4	Ub-	- 10 V	< 1 mA
	5	NTC	< 3.5 V	< 0.15 mA
	6	NTC	< 3.5 V	< 0.15 mA
	7	---	---	---

Plug from the front:

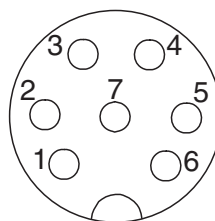

What can Xylem do for you?

We're a global team unified in a common purpose: creating innovative solutions to meet our world's water needs. Developing new technologies that will improve the way water is used, conserved, and re-used in the future is central to our work. We move, treat, analyze, and return water to the environment, and we help people use water efficiently, in their homes, buildings, factories and farms. In more than 150 countries, we have strong, long-standing relationships with customers who know us for our powerful combination of leading product brands and applications expertise, backed by a legacy of innovation.

For more information on how Xylem can help you, go to xylem.com.



Service and Returns:

Xylem Analytics Germany
Sales GmbH & Co. KG
WTW
Dr.-Karl-Slevogt-Str. 1
82362 Weilheim
Germany

Tel.: +49 881 183-325
Fax: +49 881 183-414
E-Mail wtw.rma@xylem.com
Internet: www.WTW.com



Xylem Analytics Germany GmbH
Dr.-Karl-Slevogt-Str. 1
82362 Weilheim
Germany