

ba72304de **Fremdsteuerung**
External Control

für / for

MultiLine P3, P4
Taschengeräte / *Pocket meters* `340
Taschengeräte / *Pocket meters* ´340i
Feldgeräte / *field meters* ´197i
inoLab Level 2

**Fremdsteuerung MultiLine P3,P4
Taschengeräte ´340
Taschengeräte ´340i
Feldgeräte ´197i
inoLab Level2**

29.5.01

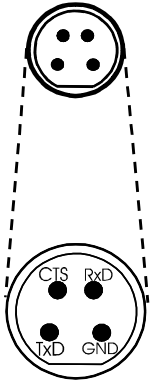

Für MultiLine P3_P4, Taschengerätereihe ´340, 340i, Feldgeräte ´197i und inoLab Level2 ist eine Fremdsteuerung über die serielle Schnittstelle vorgesehen. Fremdsteuerung ist nur über das Fremdsteuerkabel AK340/B möglich (nicht über AK325/B).

Alle Verbinder sind in Draufsicht dargestellt !!!

↓
Rechner mit 9pol RS232-Connector
werden direkt mit AK340 verbunden

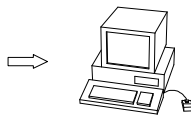
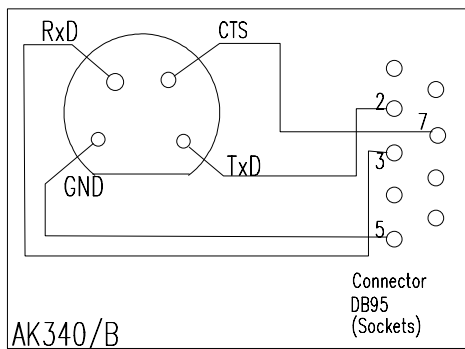

↓
Rechner mit 25pol. RS232-Connector werden
mit AK340/B + Adaptor 9/25 verbunden

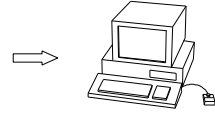
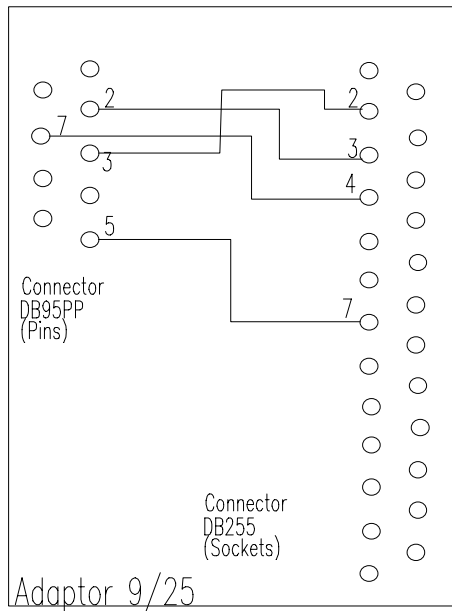

Format der Fremdsteuerbefehle:

Es gibt zwei Befehle für die Fremdsteuerung der Geräte:

1. Die „K“ - Befehle, die eine Gerätesteuerung über Simulation von Tastendrücken ermöglichen.
2. Die „D“ - Befehle, die einen Dump des Gerätedisplayinhaltes ermöglichen.

Dadurch können über RS232 alle Funktionen der Geräte gesteuert werden und die komplette Displayanzeige ausgelesen werden.

Allgemeiner Ablauf:

- Senden einer ASCII-Zeichenkette mit Abschluß CR . Format siehe hinten.
- Der Fremdsteuerbefehl wird ausgeführt
- Der Fremdsteuerbefehl wird mit „*“ „CR“ „LF“ „>“ markiert zurückgesendet
- Beim „D“-Befehl werden zusätzlich Displaydaten zurückgesendet
- Wenn ein nicht bekannter Befehl oder nicht erlaubte Bereiche für die Befehlsparameter gesendet wurden, wird keine Aktion ausgeführt und „?“ zurückgesendet.

1.Key-Befehle (K.x):

Über den Befehl „K“ kann jeder Tastendruck simuliert werden. Die Tastatur besteht aus 9 direkten Tastenfunktionen und 8 Doppeltastenfunktionen. Zusätzlich sind über die Fremdsteuerung weitere Funktionen implementiert.(s.u.)
Dadurch lassen sich die Geräte komplett fremdsteuern.

Befehlsformat:

'K'+'.'+Zahlenwert+CR

z.B: Sendestring: „K“ „.“ „7“ „CR“
 Rücksendestring: „K“ „.“ „7“ „*“ „CR“ „LF“ „>“
 Aktion Druck der Taste RUN/ENTER wird simuliert

Tastencodierung MultiLine P3,P4, TG-Serie 340, 340i, FG-Serie 197i

Codierung	Funktion
K.1	Tastendruck Taste (Û)
K.2	Tastendruck Taste (RCL)
K.3	Tastendruck Taste (M/pH/mV/O2/Kappa/ISE)
K.4	Tastendruck Taste (Ú)
K.5	Tastendruck Taste (STO)
K.6	Tastendruck Taste (CAL/C)
K.7	Tastendruck Taste (RUN/ENTER)
K.8	Tastendruck Taste (AR/TC)
K.9	Tastendruck Taste (ON/OFF)
K.10	Doppel-Tastendruck Taste (RUN/ENTER) + Taste (Û)
K.11	Doppel-Tastendruck Taste (RUN/ENTER) + Taste (RCL)
K.12	Doppel-Tastendruck Taste (RUN/ENTER) + Taste (M/pH/mV/O2/Kappa/ISE)
K.13	Doppel-Tastendruck Taste (RUN/ENTER) + Taste (Ú)
K.14	Doppel-Tastendruck Taste (RUN/ENTER) + Taste (STO)
K.15	Doppel-Tastendruck Taste (RUN/ENTER) + Taste (CAL/C)
K.16	Doppel-Tastendruck Taste (M,pH/mV/O2/Kappa/ISE) + Taste (ON/OFF)
K.17	Doppel-Tastendruck Taste (STO) + Taste (ON/OFF)
K.18	Geräteerkennung wird als ASCII-String zurückgesendet (Bei MultiLine P4 nur ab Version 1.03) pH340="10", pH340/ION="11", OXI340="20", LF340="30" MultiLine P4 = "40", MultiLine P3 pH/Ox i= "41", MultiLine P3 pH/LF = "42" pH340i = "18", pH/ION340i = "19", OXI340i = "24", Cond340i = "35" pH/Oxi340i = "45", pH/Cond340i = "49", Multi340i = "44" pH197i="60", Oxi197i="70", Cond197i="80", Multi197i="90"
K.19	Nur bei OXI340,340i, MultiLine P3 pH/Oxi, MultiLine P4, pH/Oxi340i, Multi340i , Oxi197i, Multi197i!! Der aktuelle Luftdruck in mbar wird zurückgesendet (z.B. „P= 956“)

Tastencodierung inoLab Level2

Codierung	Funktion
K.1	Tastendruck Taste (Û)
K.2	Tastendruck Taste (AR)
K.3	Tastendruck Taste (M)
K.4	Tastendruck Taste (Ú)
K.5	Tastendruck Taste (STO)
K.6	Tastendruck Taste (CAL)
K.7	Tastendruck Taste (RUN/ENTER)
K.8	Tastendruck Taste (RCL)
K.9	Tastendruck Taste (ON/OFF)
K.10	Doppel-Tastendruck Taste (RUN/ENTER) + Taste (Û)
K.11	Doppel-Tastendruck Taste (RUN/ENTER) + Taste (AR)
K.12	Doppel-Tastendruck Taste (RUN/ENTER) + Taste (M)
K.13	Doppel-Tastendruck Taste (RUN/ENTER) + Taste (Ú)
K.14	Doppel-Tastendruck Taste (RUN/ENTER) + Taste (STO)
K.15	Doppel-Tastendruck Taste (RUN/ENTER) + Taste (CAL)
K.16	Doppel-Tastendruck Taste (M) + Taste (ON/OFF)
K.17	Doppel-Tastendruck Taste (STO) + Taste (ON/OFF)
K.18	Geräteerkennung wird als ASCII-String zurückgesendet (inoLab pH Level2 = „13“, inoLab pH/ION Level2 = „14“, inoLab Oxi Level2 = „21“, inoLab Cond Level2 = „32“)
K.19 (nur inoLab Oxi	Nur bei inoLab Oxi Level2. Der aktuelle Luftdruck in mbar wird zurückgesendet

2. Display-Befehle (D.x)

Über den Befehl „D“ kann der Inhalt des Display Memory angefordert werden. Das Display Memory besteht aus 13 Bytes, in denen die Segmentinformationen gespeichert sind. (Zuordnung der Bytes zu den Displaysegmenten für die unterschiedlichen Gerätereihen siehe unten). Für jedes angesteuerte Segment im Display ist das zugeordnete Bit im Displaymemory auf „1“ gesetzt. Nicht angesteuerte Segmente liefern „0“ zurück.

Dadurch lassen sich z.B. gezielt Statusanzeigen des Displays abfragen, bzw. das komplette Display rekonstruieren.

Befehlsformat:

'D'+'.'+Zahlenwert+CR

z.B: Sendestring: „D“ „.“ „8“ „CR“
 Rücksendestring: „D“ „.“ „8“ „*“ „CR“ „LF“ „>“
 Aktion Byte Nr. 8 des Displaymemorys wird im Dezimalformat gesendet:

Displaycodierung MultiLine P3,P4, TG-Serie 340, FG-Serie 197i

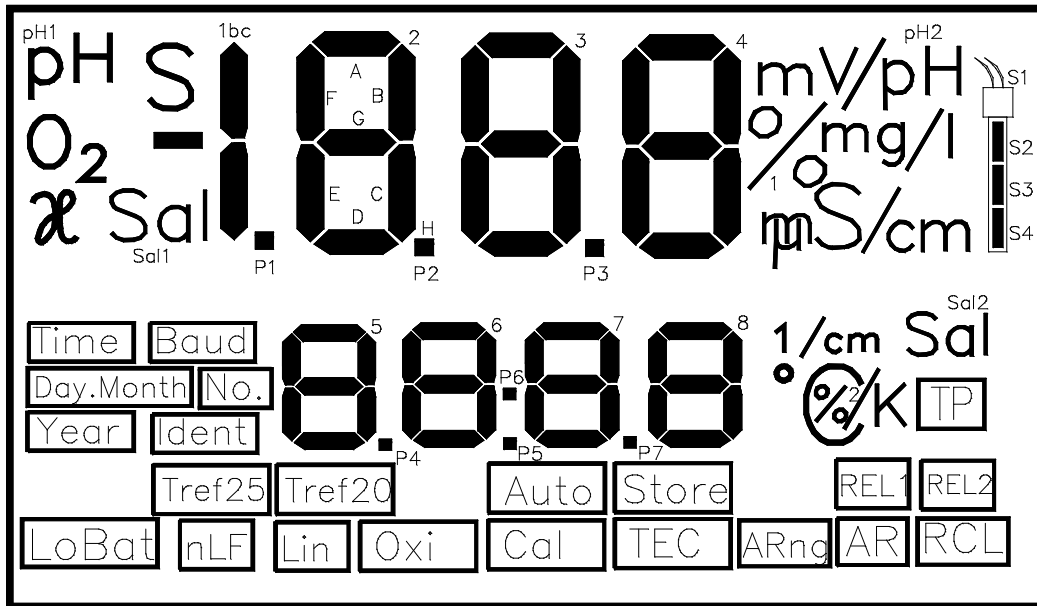

Befehl	Byte, das auf den Befehl D.x vom Gerät zurückgesendet wird							
	BIT 7 (MSB)	BIT 6	BIT 5	BIT4	BIT3	BIT2	BIT1	BIT0 (LSB)
D.0	2D	2E	2G	2F	2H, "P2"	2C	2B	2A
D.1	3D	3E	3G	3F	3H, "P3"	3C	3B	3A
D.2	4D	4E	4G	4F	4H, "m"	4C	4B	4A
D.3	5D	5E	5G	5F	5H, "P4"	5C	5B	5A
D.4	6D	6E	6G	6F	6H, "P5"	6C	6B	6A
D.5	7D	7E	7G	7F	7H, "P7"	7C	7B	7A
D.6	8D	8E	8G	8F	8H, "REL 1"	8C	8B	8A
D.7	"Sal 1"	"æ"	"O2"	"pH1"	"P1"	"1bc"	"Minus"	"S"
D.8	"mg/l"	"%1"	"pH2"	"mV"	"S1"	"S3"	"S4"	"S2"
D.9	"S/cm"	"/K"	"% 2"	"Sal 2"	"µ"	"TP"	"°C"	"1/cm"
D.10	"nLF"	"Ident"	"No."	"Baud"	"LoBat"	"Year"	"Day.Month"	"Time"
D.11	"Tref25"	"Tref20"	"Auto"	"Store"	"Lin"	"Oxi"	"Cal"	"TEC"
D.12	-----	-----	-----	"P6"	"REL 2"	"RCL"	"AR"	"ARng"

Displaycodierung inoLab pH Level2, inoLab pH/ION Level2, pH340i, pH/ION340i:

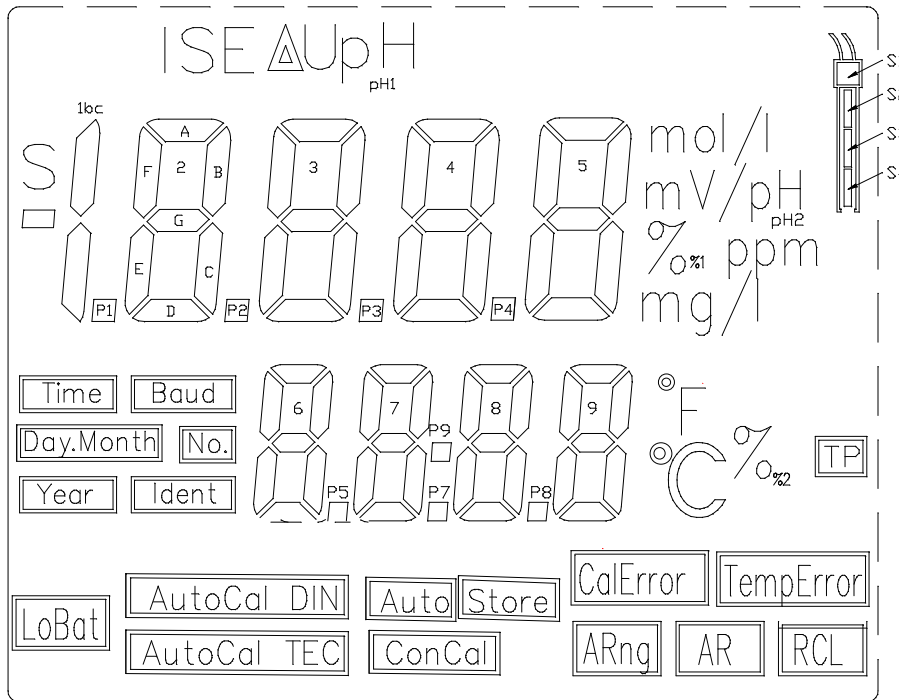

Befehl	Byte, das auf den Befehl D.x vom Gerät zurückgesendet wird							
	BIT 7 (MSB)	BIT 6	BIT 5	BIT4	BIT3	BIT2	BIT1	BIT0 (LSB)
D.0	2D	2E	2G	2F	"P2"	2C	2B	2A
D.1	3D	3E	3G	3F	"P3"	3C	3B	3A
D.2	4D	4E	4G	4F	"P4"	4C	4B	4A
D.3	5D	5E	5G	5F		5C	5B	5A
D.4	6D	6E	6G	6F	"P6"	6C	6B	6A
D.5	7D	7E	7G	7F	"P7"	7C	7B	7A
D.6	8D	8E	8G	8F	"P8"	8C	8B	8A
D.7	9D	9E	9G	9F	" "	9C	9B	9A
D.8	"mg/l"	"%1"	"mV"	"mol/l"	"S1"	"S3"	"S4"	"S2"
D.9	"ppm"	"/pH2"	"°C "	"°F"	"P1"	"1bc"	"Minus"	"S"
D.10	"LoBat"	"Year"	"Day.month"	"Time"	"P9"	"Ident"	"No."	"Baud"
D.11	"TP"	"RCL"	"ConCal"	"Arng"	"AutoCalDIN"	"AutoCalTec"	"Auto"	"Store"
D.12	"ISE"	"delta"	"U"	"pH1"	"%2"	"TempErr"	"AR"	"CalError"

Display Codierung inoLab Oxi Level2, inoLab Cond Level2:

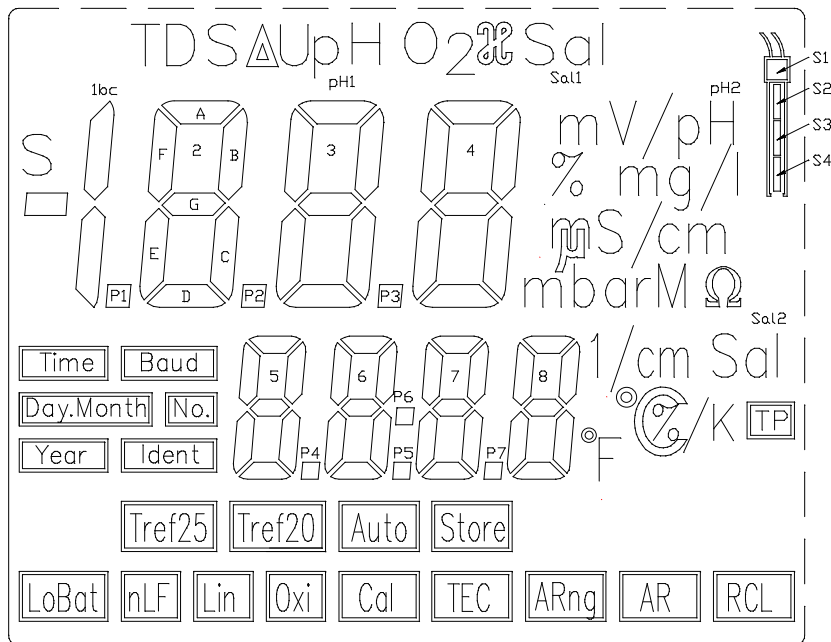

Befehl	Byte, das auf den Befehl D.x vom Gerät zurückgesendet wird							
	BIT 7 (MSB)	BIT 6	BIT 5	BIT4	BIT3	BIT2	BIT1	BIT0 (LSB)
D.0	2D	2E	2G	2F	"P2"	2C	2B	2A
D.1	3D	3E	3G	3F	"P3"	3C	3B	3A
D.2	4D	4E	4G	4F	"m"	4C	4B	4A
D.3	5D	5E	5G	5F	"P4"	5C	5B	5A
D.4	6D	6E	6G	6F	"P5"	6C	6B	6A
D.5	7D	7E	7G	7F	"P7"	7C	7B	7A
D.6	8D	8E	8G	8F	"°F"	8C	8B	8A
D.7	"pH1"	"O2"	"χ"	"Sal1"	"P1"	"1bc"	"Minus"	"S"
D.8	"μ"	"S/cm"	"%1"	"mV"	"S1"	"S3"	"S4"	"S2"
D.9	"mbar"	"MΩ"	"mg/l"	"pH2"	"%/K"	"°C"	"Sal2"	"1/cm"
D.10	"nLF"	"Ident"	"No."	"Baud"	"LoBat"	"Year"	"Day.Month"	"Time"
D.11	"Tref25"	"Tref20"	"Auto"	"Store"	"Lin"	"Oxi"	"Cal"	"Tec"
D.12	"U"	"delta"	"TDS"	"P6"	"TP"	"RCL"	"AR"	"ARng"

Display Codierung Oxi340i, Cond340i, pH/Oxi340i, pH/Cond340i, Multi340i:

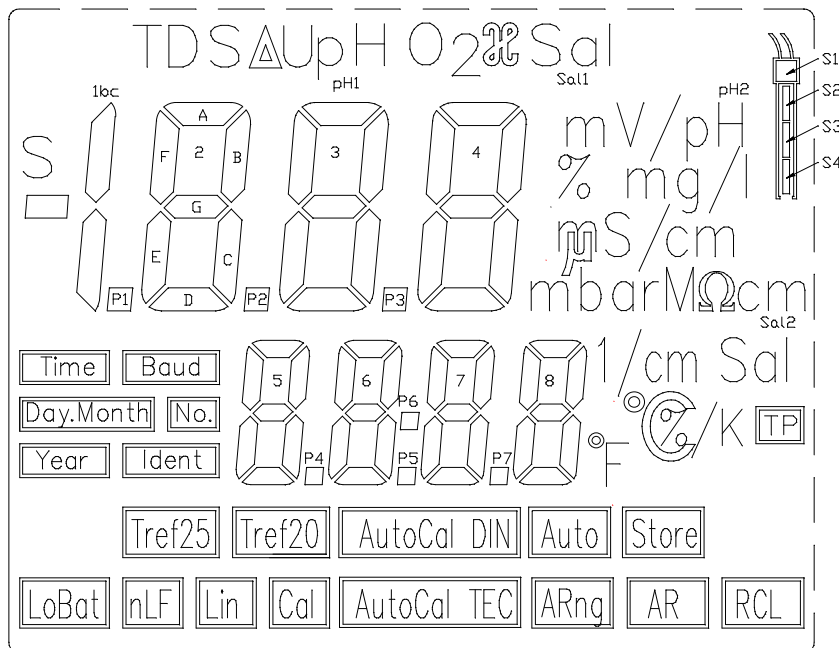

Befehl	Byte, das auf den Befehl D.x vom Gerät zurückgesendet wird							
	BIT 7 (MSB)	BIT 6	BIT 5	BIT4	BIT3	BIT2	BIT1	BIT0 (LSB)
D.0	2D	2E	2G	2F	"P2"	2C	2B	2A
D.1	3D	3E	3G	3F	"P3"	3C	3B	3A
D.2	4D	4E	4G	4F	"m"	4C	4B	4A
D.3	5D	5E	5G	5F	"P4"	5C	5B	5A
D.4	6D	6E	6G	6F	"P5"	6C	6B	6A
D.5	7D	7E	7G	7F	"P7"	7C	7B	7A
D.6	8D	8E	8G	8F	"°F"	8C	8B	8A
D.7	"pH1"	"O2"	"χ"	"Sal1"	"P1"	"1bc"	"Minus"	"S"
D.8	"μ"	"S/cm"	"%1"	"mV"	"S1"	"S3"	"S4"	"S2"
D.9	"mbar"	"MΩ*cm"	"mg/l"	"/pH2"	"%/K"	"°C"	"Sal2"	"1/cm"
D.10	"nLF"	"Ident"	"No."	"Baud"	"LoBat"	"Year"	"Day,Month"	"Time"
D.11	"Tref25"	"Tref20"	"Auto"	"Store"	"Lin"	"AutoCalDin"	"Cal"	"AutoCalTec"
D.12	"U"	"delta"	"TDS"	"P6"	"TP"	"RCL"	"AR"	"ARng"

**Remote Control MultiLine P3,P4
 Handheld ´340
 Handheld ´340i
 Fieldmeter ´197i
 inoLab Level2**

29.5.01

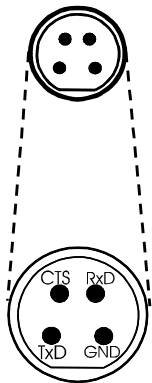

For MultiLine P3_P4, handheld series ´340/´340i, fieldmeter ´197i, inoLab Level2 series a remote control via the serial interface is provided. Remote control, however, is only possible via the remote control cable AK340/B. (not possible with AK325/B)

All connectors are shown in front sight !!!

↓
 Rechner mit 9pol RS232-Connector
 werden direkt mit AK340 verbunden

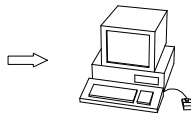
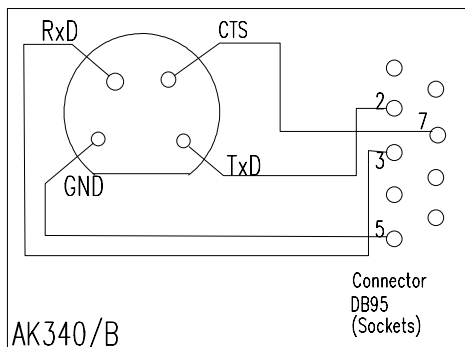

↓
Rechner mit 25pol. RS232-Connector werden
mit AK340/B + Adaptor 9/25 verbunden

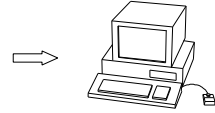
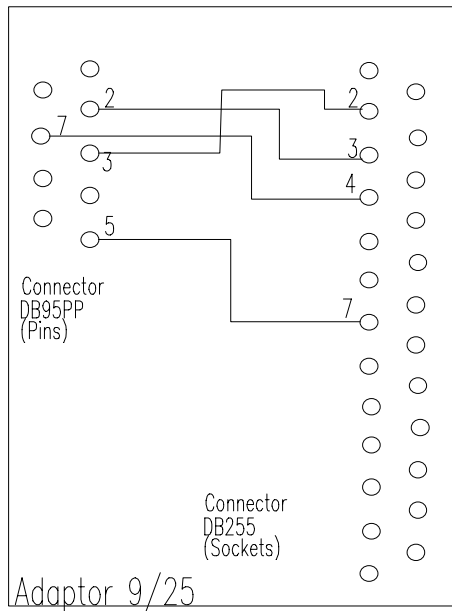

Format of the remote control commands:

There are two commands to operate the meter by remote control:

1. The „K“ commands, which facilitate to control the meter by simulating key pressure.
2. The „D“ commands, which facilitate a dump of the contents of the meter display.

Thus, via the RS232 all functions of the meter can be controlled and the complete display indication can be read out.

General course:

- Transmission of an ASCII string with end CR . Format see below.
- The remote control command is carried out.
- The remote control command is marked with "*" "CR" "LF" ">" and returned.
- In case of a "D" command display data are sent back.
- If an unknown command or forbidden ranges for the command parameters are sent no action is carried out and "?" is sent back.

1.Key-Commands (K.x):

With the command „K“ every keystroke can be simulated. The keys consist of 9 direkt key functions and 8 double key functions. Additionally more functions are implemented with the remote control. (s.u.)
Thus the meter can be remote controlled completely.

Format of command:

'K'+'.'+number+CR

e.g: Transmission string: „K“ „.“ „7“ „CR“
Return string: „K“ „.“ „7“ „*“ „CR“ „LF“ „>“
Action Pressing of key RUN/ENTER is simulated

Keycoding MultiLine P3,P4, TG-Series 340,340i, Field 197i

Coding	Function
K.1	Key pressure Key (Û)
K.2	Key pressure Key (RCL)
K.3	Key pressure Key (M,pH/mV/O2/Kappa/ISE)
K.4	Key pressure Key (Û)
K.5	Key pressure Key (STO)
K.6	Key pressure Key (CAL/C)
K.7	Key pressure Key (RUN/ENTER)
K.8	Key pressure Key (AR/TC)
K.9	Key pressure Key (ON/OFF)
K.10	Double key pressure Key (RUN/ENTER) + Taste (Û)
K.11	Double key pressure Key (RUN/ENTER) + Taste (RCL)
K.12	Double key pressure Key (RUN/ENTER) + Taste (M,pH/mV/O2/Kappa/ISE)
K.13	Double key pressure Key (RUN/ENTER) + Taste (Û)
K.14	Double key pressure Key (RUN/ENTER) + Taste (STO)
K.15	Double key pressure Key (RUN/ENTER) + Taste (CAL/C)
K.16	Double key pressure Key (M,pH/mV/O2/Kappa/ISE) + Taste (ON/OFF)
K.17	Double key pressure Key (STO) + Taste (ON/OFF)
K.18	Signature of the meter is sent back as ASCII (With MultiLine P4 only up from Version 1.03) pH340="10", pH340/ION="11", OXI340="20", LF340="30" MultiLine P4 = "40", MultiLine P3 pH/Ox i= "41", MultiLine P3 pH/LF = "42" pH340i = "18", pH/ION340i = "19", OXI340i = "24", Cond340i = "35" pH/Oxi340i = "45", pH/Cond340i = "49", Multi340i = "44" pH197i="60", Oxi197i="70", Cond197i="80", Multi197i="90"
K.19	Only at OXI340,340i, MultiLine P3 pH/Oxi, MultiLine P4, pH/Oxi340i and Multi340i, Oxi197i, Multi197i!! The actual air pressure in mbar is sent back (e.g. „P= 956“)

Keycoding inoLab Level2

Coding	Function
K.1	Key pressure Key (Û)
K.2	Key pressure Key (AR)
K.3	Key pressure Key (M)
K.4	Key pressure Key (Û)
K.5	Key pressure Key (STO)
K.6	Key pressure Key (CAL)
K.7	Key pressure Key (RUN/ENTER)
K.8	Key pressure Key (RCL)
K.9	Key pressure Key (ON/OFF)
K.10	Double key pressure Key (RUN/ENTER) + Key (Û)
K.11	Double key pressure Key (RUN/ENTER) + Key (AR)
K.12	Double key pressure Key (RUN/ENTER) + Key (M)
K.13	Double key pressure Key (RUN/ENTER) + Key (Û)
K.14	Double key pressure Key (RUN/ENTER) + Key (STO)
K.15	Double key pressure Key (RUN/ENTER) + Key (CAL)
K.16	Double key pressure Key (M) + Key (ON/OFF)
K.17	Double key pressure Key (STO) + Key (ON/OFF)
K.18	Signature of the meter is sent back as ASCII ("13"=inoLab pH Level2, "14"=inoLab pH/ION Level2, "21"=inoLab Oxi Level2, "32"=inoLab Cond Level2)
K.19	Only inoLab Oxi Level2. The actual air pressure in mbar is sent back. (i.e. „P= 956“)

2. Display-Commands (D.x)

With the "D" command the contents of the Display memory can be requested. The Display memory consists of 13 bytes in which the segment information is stored. (Assignment of the bytes to the display segments see below.) For each segment in the display that is addressed the bit in the display memory assigned to it is set to "1". Segments that are not addressed return "0".
By this, for example, status indications of the display can be requested or the complete display can be restored.

Format of command:

'D'+'.'+number+CR

e.g.: Transmission string: „D“ „.“ „8“ „CR“

Return string: „D“ „.“ „8“ „*“ „CR“ „LF“ „>“

Action: Byte Nr. 8 of the display memory is transmitted in decimal format

Displaycoding MultiLine P3,P4, TG-Serie 340, Field 197i

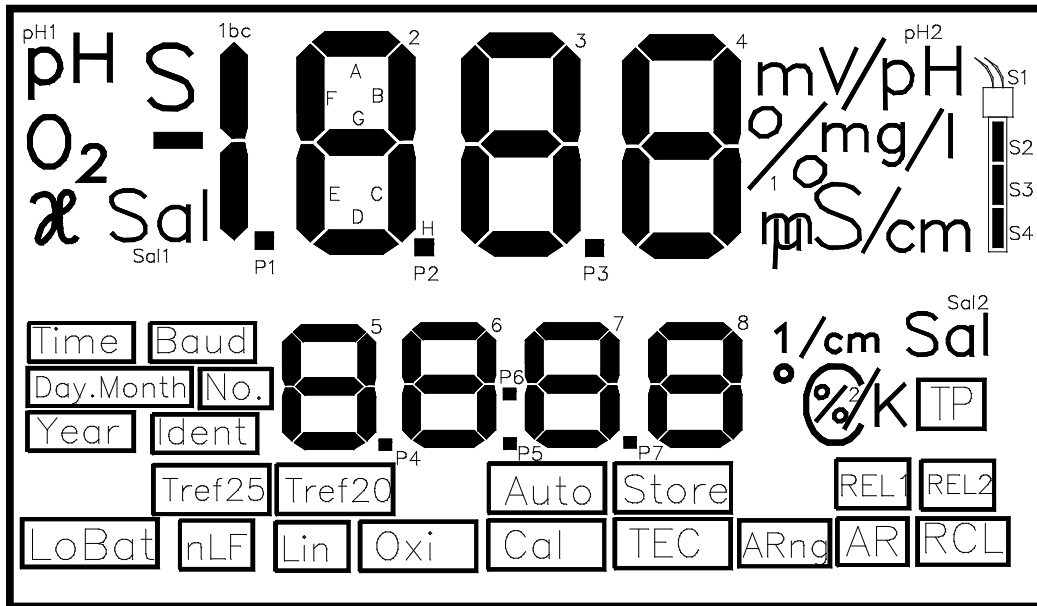

Befehl	Byte, das auf den Befehl D.x vom Gerät zurückgesendet wird							
	BIT 7 (MSB)	BIT 6	BIT 5	BIT4	BIT3	BIT2	BIT1	BIT0 (LSB)
D.0	2D	2E	2G	2F	2H, "P2"	2C	2B	2A
D.1	3D	3E	3G	3F	3H, "P3"	3C	3B	3A
D.2	4D	4E	4G	4F	4H, "m"	4C	4B	4A
D.3	5D	5E	5G	5F	5H, "P4"	5C	5B	5A
D.4	6D	6E	6G	6F	6H, "P5"	6C	6B	6A
D.5	7D	7E	7G	7F	7H, "P7"	7C	7B	7A
D.6	8D	8E	8G	8F	8H, "REL 1"	8C	8B	8A
D.7	"Sal 1"	"æ"	"O2"	"pH1"	"P1"	"1bc"	"Minus"	"S"
D.8	"mg/l"	"%1"	"pH2"	"mV"	"S1"	"S3"	"S4"	"S2"
D.9	"S/cm"	"/K"	"% 2"	"Sal 2"	"µ"	"TP"	"°C"	"1/cm"
D.10	"nLF"	"Ident"	"No."	"Baud"	"LoBat"	"Year"	"Day.Month"	"Time"
D.11	"Tref25"	"Tref20"	"Auto"	"Store"	"Lin"	"Oxi"	"Cal"	"TEC"
D.12	-----	-----	-----	"P6"	"REL 2"	"RCL"	"AR"	"ARng"

Displaycoding inoLab pH Level2, inoLab pH/ION Level2, pH340i, pH/ION340i:

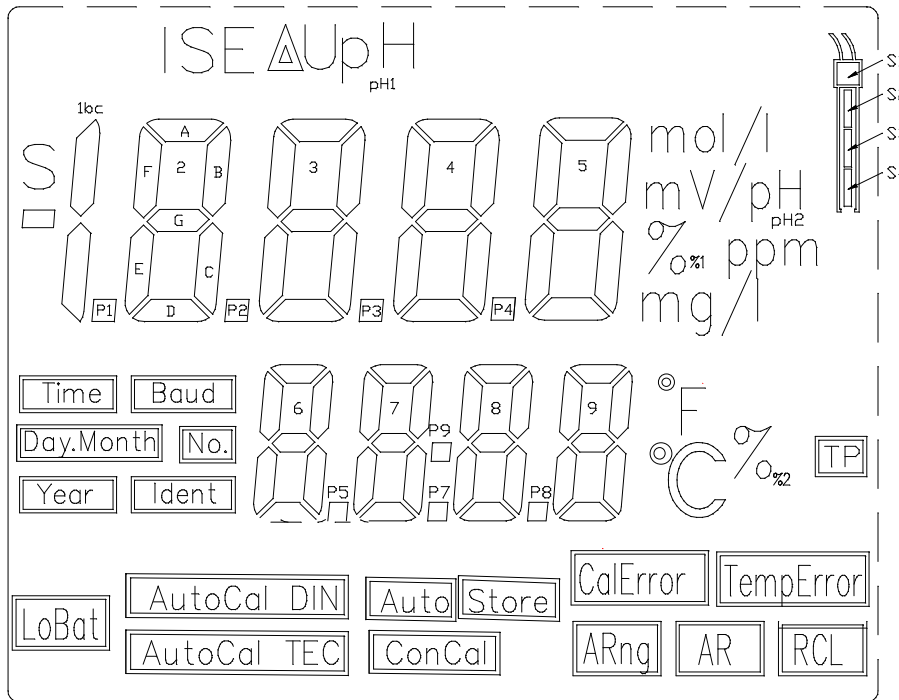

Befehl	Byte, das auf den Befehl D.x vom Gerät zurückgesendet wird							
	BIT 7 (MSB)	BIT 6	BIT 5	BIT4	BIT3	BIT2	BIT1	BIT0 (LSB)
D.0	2D	2E	2G	2F	"P2"	2C	2B	2A
D.1	3D	3E	3G	3F	"P3"	3C	3B	3A
D.2	4D	4E	4G	4F	"P4"	4C	4B	4A
D.3	5D	5E	5G	5F		5C	5B	5A
D.4	6D	6E	6G	6F	"P6"	6C	6B	6A
D.5	7D	7E	7G	7F	"P7"	7C	7B	7A
D.6	8D	8E	8G	8F	"P8"	8C	8B	8A
D.7	9D	9E	9G	9F	"	9C	9B	9A
D.8	"mg/l"	"%1"	"mV"	"mol/l"	"S1"	"S3"	"S4"	"S2"
D.9	"ppm"	"/pH2"	"°C "	"°F"	"P1"	"1bc"	"Minus"	"S"
D.10	"LoBat"	"Year"	"Day.month"	"Time"	"P9"	"Ident"	"No."	"Baud"
D.11	"TP"	"RCL"	"ConCal"	"Arng"	"AutoCalDIN"	"AutoCalTec"	"Auto"	"Store"
D.12	"ISE"	"delta"	"U"	"pH1"	"%2"	"TempErr"	"AR"	"CalError"

Display Coding inoLab Oxi Level2, inoLab Cond Level2:

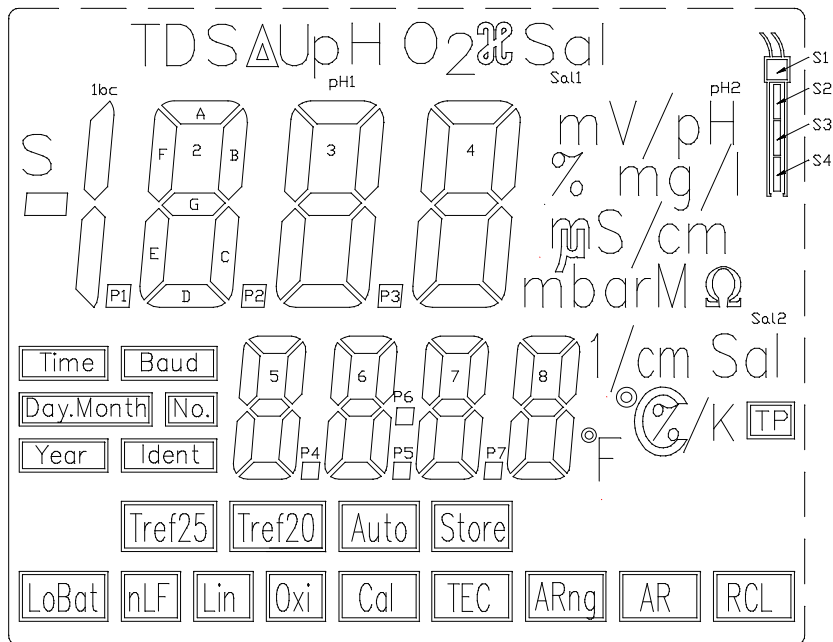

Befehl	Byte, das auf den Befehl D.x vom Gerät zurückgesendet wird							
	BIT 7 (MSB)	BIT 6	BIT 5	BIT4	BIT3	BIT2	BIT1	BIT0 (LSB)
D.0	2D	2E	2G	2F	"P2"	2C	2B	2A
D.1	3D	3E	3G	3F	"P3"	3C	3B	3A
D.2	4D	4E	4G	4F	"m"	4C	4B	4A
D.3	5D	5E	5G	5F	"P4"	5C	5B	5A
D.4	6D	6E	6G	6F	"P5"	6C	6B	6A
D.5	7D	7E	7G	7F	"P7"	7C	7B	7A
D.6	8D	8E	8G	8F	"°F"	8C	8B	8A
D.7	"pH1"	"O2"	"χ"	"Sal1"	"P1"	"1bc"	"Minus"	"S"
D.8	"μ"	"S/cm"	"%1"	"mV"	"S1"	"S3"	"S4"	"S2"
D.9	"mbar"	"MΩ"	"mg/l"	"pH2"	"%/K"	"°C"	"Sal2"	"1/cm"
D.10	"nLF"	"Ident"	"No."	"Baud"	"LoBat"	"Year"	"Day.Month"	"Time"
D.11	"Tref25"	"Tref20"	"Auto"	"Store"	"Lin"	"Oxi"	"Cal"	"Tec"
D.12	"U"	"delta"	"TDS"	"P6"	"TP"	"RCL"	"AR"	"ARng"

Display Coding Oxi340i, Cond340i, pH/Oxi340i, pH/Cond340i, Multi340i:

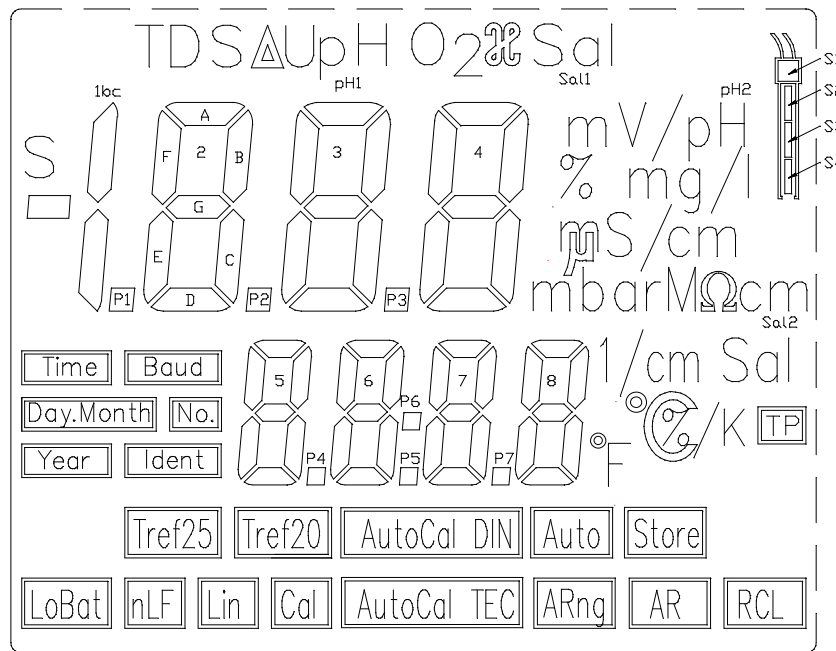

Befehl	Byte, das auf den Befehl D.x vom Gerät zurückgesendet wird							
	BIT 7 (MSB)	BIT 6	BIT 5	BIT 4	BIT 3	BIT 2	BIT 1	BIT 0 (LSB)
D.0	2D	2E	2G	2F	"P2"	2C	2B	2A
D.1	3D	3E	3G	3F	"P3"	3C	3B	3A
D.2	4D	4E	4G	4F	"m"	4C	4B	4A
D.3	5D	5E	5G	5F	"P4"	5C	5B	5A
D.4	6D	6E	6G	6F	"P5"	6C	6B	6A
D.5	7D	7E	7G	7F	"P7"	7C	7B	7A
D.6	8D	8E	8G	8F	"°F"	8C	8B	8A
D.7	"pH1"	"O2"	"χ"	"Sal1"	"P1"	"1bc"	"Minus"	"S"
D.8	"μ"	"S/cm"	"%1"	"mV"	"S1"	"S3"	"S4"	"S2"
D.9	"mbar"	"MΩ*cm"	"mg/l"	"/pH2"	"%/K"	"°C"	"Sal2"	"1/cm"
D.10	"nLF"	"Ident"	"No."	"Baud"	"LoBat"	"Year"	"Day.Month"	"Time"
D.11	"Tref25"	"Tref20"	"Auto"	"Store"	"Lin"	"AutoCalDin"	"Cal"	"AutoCalTec"
D.12	"U"	"delta"	"TDS"	"P6"	"TP"	"RCL"	"AR"	"ARng"